











# 聯軸器產品檢索

## COUPLING GUIDE











### 撓性聯軸器

品號 Item	材質 Material	高扭力 High Torque	低慣性 Low Inertia	零背隙 Zero Backlash	高剛性 High Rigid	絕緣性 High Insulation	抗蝕性 Erode Resistance	抗震性 Anti-seismic	偏心佳 High Eccentric	偏角佳 High Deflection
 SGH-C	AL	●	●	●	●					
 SGS-C	AL	●	●	●	●					
 SGL-C	AL	●	●	●	●					●
 SGB-C	AL	●	●	●	●					
 SGM-C	AL	●	●	●	●					●
 SGW-C	AL	●	●	●	●					●
 SAP	S45C	●	●	●	●			●	●	
 SAP-C	S45C	●	●	●	●			●	●	
 SRJ	AL	●	●		●			●		
 SRJ-C	AL	●	●		●			●		
 SRJS	S45C	●	●		●			●		

# 聯軸器產品檢索

## COUPLING GUIDE



### 撓性聯軸器

品號 Item	材質 Material	高扭力 High Torque	低慣性 Low Inertia	零背隙 Zero Backlash	高剛性 High Rigid	絕緣性 High Insulation	抗蝕性 Erode Resistance	抗震性 Anti-seismic	偏心率佳 High Eccentric	偏角佳 High Deflection
 SCT	AL	●	●	●						●
 SCTS	SUS	●	●	●	●		●			
 SCT-C	AL	●	●	●						●
 SCTS-C	SUS	●	●	●	●		●			
 SWS	AL	●	●	●						●
 SWSS	SUS	●	●	●	●		●			●
 SWS-C	AL	●	●	●						●
 SWSS-C	SUS	●	●	●	●		●			
 SCPB	PLASTIC		●	●		●	●			●
 SMT	AL		●	●						●
 SMT-C	AL		●	●						●

# 聯軸器產品檢索

## COUPLING GUIDE

### ■ 撓性聯軸器

品號 Item	材質 Material	高扭力 High Torque	低慣性 Low Inertia	零背隙 Zero Backlash	高剛性 High Rigid	絕緣性 High Insulation	抗蝕性 Erode Resistance	抗震性 Anti- seismic	偏心佳 High Eccentric	偏角佳 High Deflection
 SRJS-C	S45C	●	●		●			●		
 SOT	AL	●	●		●	●		●	●	●
 SOT-C	AL	●	●		●	●		●	●	●

### ■ 剛性聯軸器

品號 Item	材質 Material	高扭力 High Torque	低慣性 Low Inertia	零背隙 Zero Backlash	高剛性 High Rigid	絕緣性 High Insulation	抗蝕性 Erode Resistance	抗震性 Anti- seismic	偏心佳 High Eccentric	偏角佳 High Deflection
 SCG	AL	●	●	●	●					
 SCGS	SUS	●	●	●	●					
 SCG-C	AL	●	●	●	●					
 SCGS-C	SUS	●	●	●	●					

### 聯軸器介紹 Introduction to Coupling

聯軸器是連接兩個不同機器的軸，使之供回轉，在容許範圍內的軸向、平行、角度偏差位移時仍能正常的運作、並傳遞安全轉矩的一種機械裝置。

A coupling is a mechanical device that serves to connect two different machines for rotating and for the normal operation within the permissible axial, parallel and angle deviation ranges, and transmits safe torques.

### 使用目的 Purposes

1. 連結二個個別製造的旋轉機器的軸 (如馬達和螺桿)，在需要更換或維修時可以拆卸。
2. 增加機械的可撓性，允許軸有小幅度的偏差。
3. 聯軸器為一種安全裝置，保護機構免於撞損。
4. 調整或改善轉元件的振動特性。
5. 功率或轉矩的傳達。

1. To link the axes of two independent rotating machines (such as motor and screw), and allow the disassembly for replacement or repair.
2. To increase the flexibility of machines and allow the minor deviation of axes.
3. A coupling is a safety device to protect the machines from being damaged.
4. To adjust or improve the vibration characteristics of rotating components.
5. To realize the transmission of power or torque.



### 聯軸器種類 The kind of coupling

一般聯軸器可分為撓性及剛性聯軸器兩大類。

#### 1. 撓性聯軸器 (Flexible Coupling):

當動力傳達、兩軸要配置成一直線發生困難時，或者兩軸之安裝非常簡單時，應使用可撓性聯軸器，它具有緩和衝擊、吸收平行、偏角、軸向位差、改善系統傳動動力特性的功能，因此在安裝時，即使軸發生少許之偏差，而軸承也不會有勉強之情形，在市場上應用非常廣泛。

#### 2. 剛性聯軸器 (Rigid Coupling):

可精確的傳遞扭矩，為一無法造成偏心、偏角之元件，能使被連接的兩軸固定成為一體，因此使用上同心度必需要求非常高。

**The coupling can be divided into two major categories: flexible coupling and rigid coupling.**

#### 1. Flexible Coupling:

Flexible coupling is applied when it is difficult to configure the power transmission and two axes into a straight line or when the installation of two axes is very simple. Flexible coupling has the functions of alleviating the impact, allowing the parallel, angle and axial potential differences as well as improving the transfer power characteristics of the system. That is to say, such coupling can ensure that the axes rotate smoothly even when there are minor deviations in installation. The flexible coupling is widely used.

#### 2. Rigid Coupling:

Rigid coupling is the component that can transmit torques accurately, completely prevent the deflective angle and eccentricity as well as integrate the two axes connected into a unit; therefore, the application of rigid coupling has a high requirement for concentricity.

## 聯軸器之特性

### FEATURES

#### 設計上的確認事項

#### Confirmations on Design

依據機械特性、系統運作來選用適合的聯軸器型式：

An appropriate coupling is selected according to mechanical properties and operation of the system:

##### ● 扭力的大小 Torque :

聯軸器的扭力應為傳動扭力最大值的兩倍。例：若傳動扭力值為5N.m,則應選擇扭力值10N.m(型錄標示為“一般扭力”區),選擇聯軸器時,不應超過容許扭力值。材質以鋼質的扭力為佳。

The torque of a coupling must be twice the maximum of the transmission torque. For example: if the drive torque is 5N.m, you should select a torque of 10N.m (labeled "general torque" on the catalog). In selecting the coupling, it should be within the permissible torque. The steel torque is the best.

##### ● 撓性與剛性 Flexible and rigid:

撓性聯軸器可吸收平行偏差、角度偏差、軸向偏差；剛性聯軸器則無此特性，因此兩軸的精準度必需非常高，否則易造成軸心斷裂。

Flexible coupling can absorb parallel deviation, angle deviation and axial deviation. Rigid coupling does not have this function; therefore, in using rigid coupling, the accuracies of the two axes must be very high. Otherwise, fracture of the axes can easily happen.

##### ● 使用的環境 Application environment :

需慎選聯軸器之材質是否堪負荷高低溫、耐酸鹼、空間大小...等。

It needs to take into account whether the selected coupling is suitable for the environment of high and low temperature, acid-base, space size, etc.

##### ● 有無背隙 With/without backlash :

中間有橡膠之緩衝材均有背隙的存在，要判斷機構是否可承受背隙。

Whenever the rubber cushion is available in the middle, the coupling experiences backlash; whether the body can withstand the backlash needs to be determined.

##### ● 絕緣性 Insulation :

需選擇工程塑膠類聯軸器才可絕緣。

Only engineering plastic couplings have insulation function.

##### ● 抗震性 Shock resistance :

聯軸器中間有工程塑膠、橡膠之材質較易吸收震動；中間為金屬彈片夾之；剛性聯軸器則毫無抗震性。

When the coupling contains engineering plastic or rubber materials in the middle, its shock resistance is better, followed by coupling with metal sheets, and then rigid coupling without shock resistance function.

##### ● 可承受選大轉速 High speed resistance :

設計上請參考規格表中的容許值，否則易影響聯軸器壽命。

In design, please refer to the permissible values in the specifications or the lifespan of the coupling will be shortened.

##### ● 孔徑範圍是否適用 Applicable aperture range :

請選擇型錄內所載的容許孔徑為主，過大、過小或兩端差距太大，可能損及軸心、導致斷裂。

Please select couplings within the permissible apertures described in the catalog. Couplings with too large or too small aperture or too big a gap between both ends may damage the axes or lead to fracture.

#### 聯軸器的異常情形

#### Abnormalities of coupling

聯軸器是一種不需保養的構件，平常只需注意聯軸器是否有磨損或疲勞的徵兆、螺絲是否鬆動、異常雜音及振動搖擺的情形發生，若有異常，請立刻停止運轉，確認中心是否有校正準確、慣性是否過大、螺絲有無鎖緊。為了提昇機構的壽命，在更換下一個聯軸器之前，先了解其造成損壞的原因，再來選擇更適合的聯軸器。

The coupling is a maintenance-free component but attention needs to be paid to the following : whether the coupling has signs of wear or fatigue ; whether the screw is loose, or has abnormal noise and vibration. In case of please shut down the machines

to confirm whether the center is calibrated, whether the inertia is too large and whether the screws are locked. To extend the lifespan of the coupling, please find the reason for the damage before replacing with new coupling, and then select a more suitable coupling.

## 聯軸器的固定方式

## Fixing of Coupling

### ● 止付螺絲固定式 Fixed by set screw :

係以四根固定止付螺絲以 $90^\circ$  或 $120^\circ$  角固定於軸心上，體積小、安裝容易、成本低，但因機械長時間的轉動、衝擊而使螺絲鬆脫、軸心表面容易有螺絲壓痕、拆卸困難。此固定方式成本低。

The method is to fix the coupling with four set screws to the axes at  $90^\circ$  or  $120^\circ$ , characterized by small size, easy to install and low cost; however, the long-term rotation and impact of the machines may loosen the screws, leave screw marks on the axis surface and lead to difficult disassembly. Low-cost is the advantage of this method.

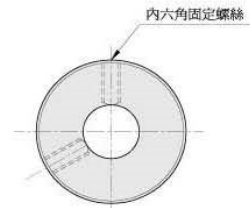

圖一 固定螺絲式 Set screw type

### ● 夾緊式 Fixed by clamping :

聯軸器雙邊各有切開之溝槽形成彈性作用，並在夾軸兩邊插入二或四支有頭內六角螺絲，使溝槽縮緊住軸心；拆卸容易、不易損傷軸心，有較佳的穩定、保持力。

Both sides of the coupling have cut grooves that are flexible; two or four socket head screws are inserted into two sides of the clamp to allow the groove to tighten the axes. The method has the advantages of easy disassembly, protection of axis, and better stability and maintaining.

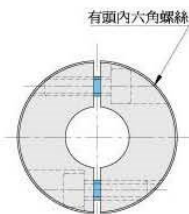

圖二 夾緊式 clamp type

### ● 鍵槽型 Keyway :

止付螺絲固定式及夾緊式皆可加工鍵槽，利用鍵的嵌合，防止滑動，適合高扭矩之機構。

Both the method of fixation by set screw and fixation by clamping allow the processing of keyways. The inosculating of keyways can prevent sliding, which is suitable for machines with high torques.

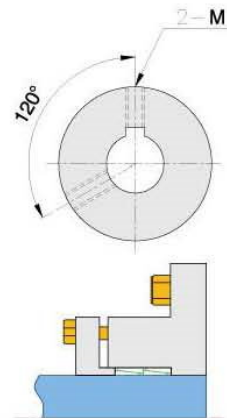

### ● 免鍵式壓環固定式 Fixed by free-button compression ring :

利用壓環逼緊軸心，以致收合夾緊。

The compression ring is used to tighten the axes in order to clamp the axes.

## 聯軸器偏差調整

## Adjustment of Deviation

聯軸器容許微量偏差，偏差過大會造成聯軸器及軸心斷裂，因此在機械組裝時，請注意精度平衡校正的動作，以利安裝、延長使用壽命，以提高機械效率。

The coupling allows minor deviation; large deviation may cause breakdown of the coupling and the axes; therefore, during assembly, more attention should be paid to precision flat correction, which facilitates the installation and lifespan, and increases the utilization ratio of machines.

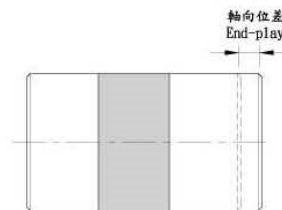
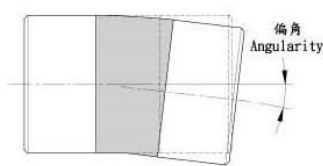
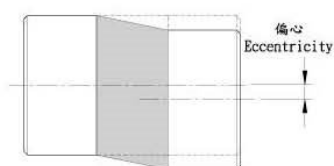

# SCT

## 開縫型 / 止付螺絲固定式 / 撓性聯軸器

# SCTS

## SLITTED / SET SCREW TYPE / FLEXIBLE COUPLING



### 材質 | Material

SCT 系列-鋁合金 Aluminum alloy  
SCTS 系列-不銹鋼 Stainless steel

### 表面處理 | Surface Treatment

SCT-陽極處理 Anodizing standard white

### 特性 | Features

- |  |  |
|--|--|
| <ol style="list-style-type: none"> <li>1. 一體成型</li> <li>2. 零背隙</li> <li>3. 剛性大</li> <li>4. 適合譯碼器、小馬力傳動機構、高精度傳動上</li> <li>5. 偏角誤差較佳</li> <li>6. 不銹鋼材質扭力較佳</li> <li>7. 固定方式：止付螺絲固定式</li> </ol> | <ul style="list-style-type: none"> <li>• One-body shape</li> <li>• Zero backlash</li> <li>• High rigid</li> <li>• Suitable for encoder、low horsepower transmission bodies and high precision transmission mechanism.</li> <li>• High deflection</li> <li>• Torque in SUS is better</li> <li>• Fixed mode : Set screw type</li> </ul> |
|--|--|

### 型號表示 | Product NO

**SCT-20- $\phi$ 5x $\phi$ 5**

型號 / Type      孔徑 / Inside dia

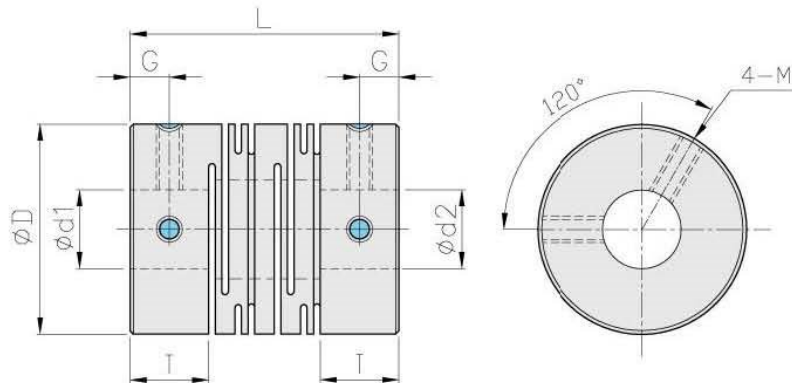

### 尺寸 | Dimension

單位 / Unit:mm

Catalog Number 型號	D	I	L	G	M	d1xd2 標準孔徑 (H7)		Mass** 重量 (g)
						Min	Max	
SCT-8	8	3.5	14.0	1.7	M2	2	4	1.3
SCT-12	12	5.0	18.5	2.5	M2.5	3	6	4.5
SCT-16	16	6.5	23.0	3.0	M3	4	8	9.5
SCT-20	20	7.5	26.0	3.0	M4	5	10	16.0
SCT-25	25	8.5	31.0	4.0	M4	5	12	30.0
SCT-32	32	12.0	41.0	6.0	M5	6	14	65.0
SCT-40	40	15	56.0	8.5	M5	8	20	120.0
SCT-50	50	18	71.0	10.5	M6	12	25	230.0
SCT-63	63	22	90.0	13.0	M8	15	35	470.0
SCTS-12	12	5	18.5	2.5	M2.5	3	6	14.0
SCTS-16	16	6.5	23.0	3.0	M3	4	8	28.0
SCTS-20	20	7.5	26.0	3.0	M4	5	10	45.0
SCTS-25	25	8.5	31.0	4.0	M4	6	12	95.0
SCTS-32	32	12	41.0	6.0	M5	6	14	220.0
SCTS-40	40	15	56.0	8.5	M5	8	20	350.0
SCTS-50	50	18	71.0	10.5	M6	12	25	700.0
SCTS-63	63	22	90.0	13.0	M8	15	35	1300.0

性能 | Specifications

單位 / Unit:mm

Catalog Number 型號	Rated Torque 一般扭力 (N.m)	Max. Torque 最大扭力 (N.m)	Max Rotational Frequency 最高回轉速 (Rpm/min)	Moment* of Inertia 慣性 (Kg · m <sup>2</sup> )	Errors of Eccentricity 容許偏心 (mm)	Errors of Angularity 容許偏角 (°)	Errors of Shaft End-Play 容許軸向位差 (mm)
SCT-8	0.1	0.2	48000	1.2x10 <sup>-8</sup>	0.10	2	±0.2
SCT-12	0.2	0.4	32000	8.3x10 <sup>-8</sup>	0.10	2	±0.3
SCT-16	0.3	0.6	24000	3.3x10 <sup>-7</sup>	0.10	2	±0.4
SCT-20	0.5	1.0	19000	9.0x10 <sup>-7</sup>	0.10	2	±0.4
SCT-25	1.0	2.0	15000	2.6x10 <sup>-6</sup>	0.15	2	±0.5
SCT-32	2.0	4.0	12000	9.6x10 <sup>-6</sup>	0.15	2	±0.5
SCT-40	5.0	10.0	9600	3.2x10 <sup>-5</sup>	0.20	2	±0.5
SCT-50	10.0	20.0	7700	1.0x10 <sup>-4</sup>	0.20	2	±0.5
SCT-63	20.0	40.0	6100	3.2x10 <sup>-4</sup>	0.20	2	±0.5
SCTS-12	0.3	0.6	32000	2.1x10 <sup>-7</sup>	0.10	2	±0.3
SCTS-16	0.5	1.0	24000	8.4x10 <sup>-7</sup>	0.10	2	±0.3
SCTS-20	1.0	2.0	19000	2.4x10 <sup>-6</sup>	0.10	2	±0.3
SCTS-25	2.0	4.0	15000	6.8x10 <sup>-6</sup>	0.15	2	±0.4
SCTS-32	3.5	7.0	12000	2.6x10 <sup>-5</sup>	0.15	2	±0.5
SCTS-40	8.0	16.0	9600	8.7x10 <sup>-5</sup>	0.20	2	±0.5
SCTS-50	15.0	30.0	7700	2.7x10 <sup>-4</sup>	0.20	2	±0.5
SCTS-63	35.0	70.0	6100	8.4x10 <sup>-4</sup>	0.20	2	±0.5

SCT.SCTS 標準孔徑 | Stock Bores

單位 / Unit:mm

Catalog Number 型號	Stock Bores 標準孔徑 d1xd2(公差H7)													
	2	3	4	5	6	6.35	8	9.525	10	12	14	15	16	18
SCT-8 SCTS-8	●	●	●											
SCT-12 SCTS-12		●	●	●	●									
SCT-16 SCTS-16			●	●	●	●	●							
SCT-20 SCTS-20				●	●	●	●	●	●					
SCT-25 SCTS-25				●	●	●	●	●	●	●				
SCT-32 SCTS-32					●	●	●	●	●	●	●			
SCT-40 SCTS-40							●		●	●	●	●	●	●
SCT-50 SCTS-50										●	●	●	●	●
SCT-63 SCTS-63												●	●	●



# SCT-C

開縫型 / 夾緊式 / 撓性聯軸器

# SCTS-C

SLITTED / CLAMP TYPE / FLEXIBLE COUPLING



### 材質 | Material

SCT-C 系列-鋁合金 Aluminum alloy  
SCTS-C 系列-不銹鋼 Stainless steel

### 型號表示 | Product NO

**SCT-20C- $\phi 5 \times \phi 5$**   
型號/Type      孔徑/Inside dia

### 表面處理 | Surface Treatment

SCT-C 陽極處理 Anodizing standard white

### 特性 | Features

1. 一體成型
  2. 零背隙
  3. 剛性大
  4. 適合譯碼器、小馬力傳動機構、高精度傳動上
  5. 偏角誤差較佳
  6. 不銹鋼材質扭力較佳
  7. 固定方式：夾緊式
- One-body shape
  - Zero backlash
  - High rigid
  - Suitable for encoder、low horsepower transmission bodies and high precision transmission mechanism.
  - High deflection
  - Torque in SUS is better
  - Fixed mode : Clamp type

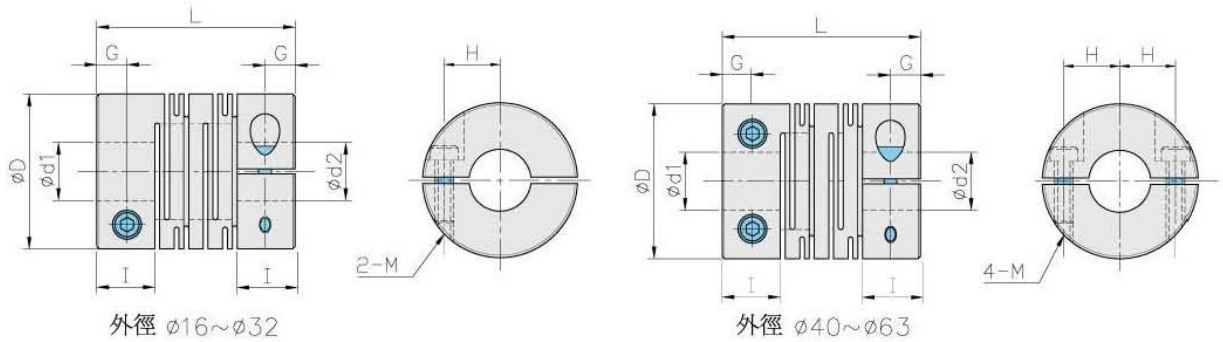

### 尺寸 | Dimension

單位 / Unit:mm

Catalog Number 型號	D	I	L	G	H	M	d1xd2 標準孔徑 (H7)		Mass** 重量 (g)
							Min	Max	
SCT-12C	12	5.0	18.5	2.5	4.0	M2	3	5	3.6
SCT-16C	16	6.5	23.0	3.25	5.0	M2.5	4	6	9.2
SCT-20C	20	7.5	26.0	3.75	6.5	M3	4	8	16.0
SCT-25C	25	8.5	31.0	4.25	9.0	M3	5	10	28.0
SCT-32C	32	12.0	41.0	6.0	11.0	M4	6	14	64.0
SCT-40C	40	15.0	56.0	8.5	14.0	M5	8	16	140.0
SCT-50C	50	18.0	71.0	10.5	18.0	M6	12	22	270.0
SCT-63C	63	22.0	90.0	13.0	24.0	M8	14	35	530.0
SCTS-12C	12	5.0	18.5	2.5	4.0	M2	3	5	10.0
SCTS-16C	16	6.5	23.0	3.25	5.0	M2.5	4	6	25.0
SCTS-20C	20	7.5	26.0	3.75	6.5	M3	5	8	43.0
SCTS-25C	25	8.5	31.0	4.25	9.0	M3	6	10	78.0
SCTS-32C	32	12.0	41.0	6.0	11.0	M4	8	14	170.0
SCTS-40C	40	15.0	56.0	8.5	14.0	M5	8	16	370.0
SCTS-50C	50	18.0	71.0	10.5	18.0	M6	12	22	750.0
SCTS-63C	63	22.0	90.0	13.0	24.0	M8	14	35	1400.0

性能 | Specifications

單位 / Unit:mm

Catalog Number 型號	Rated Torque 一般扭力 (N.m)	Max. Torque 最大扭力 (N.m)	Max Rotational Frequency 最高回轉速 (Rpm/min)	Moment* of Inertia 慣性 (Kg · m <sup>2</sup> )	Errors of Eccentricity 容許偏心 (mm)	Errors of Angularity 容許偏角 (°)	Errors of Shaft End-Play 容許軸向位差 (mm)
SCT-12C	0.2	0.4	12000	7.8x10 <sup>-8</sup>	0.10	2	± 0.3
SCT-16C	0.3	0.6	9500	3.4x10 <sup>-7</sup>	0.10	2	± 0.4
SCT-20C	0.5	1.0	7600	9.1x10 <sup>-7</sup>	0.10	2	± 0.4
SCT-25C	1.0	2.0	6100	2.6x10 <sup>-6</sup>	0.15	2	± 0.5
SCT-32C	2.0	4.0	4800	9.7x10 <sup>-6</sup>	0.15	2	± 0.5
SCT-40C	5.0	10.0	3800	3.3x10 <sup>-5</sup>	0.20	2	± 0.5
SCT-50C	10.0	20.0	3100	1.0x10 <sup>-4</sup>	0.20	2	± 0.5
SCT-63C	20.0	40.0	2400	3.2x10 <sup>-4</sup>	0.20	2	± 0.5
SCTS-12C	0.3	0.6	12000	2.2x10 <sup>-7</sup>	0.10	2	± 0.2
SCTS-16C	0.5	1.0	9500	9.0x10 <sup>-7</sup>	0.10	2	± 0.3
SCTS-20C	1.0	2.0	7600	2.5x10 <sup>-6</sup>	0.10	2	± 0.3
SCTS-25C	2.0	4.0	6100	7.1x10 <sup>-6</sup>	0.15	2	± 0.4
SCTS-32C	3.5	7.0	4800	2.7x10 <sup>-5</sup>	0.15	2	± 0.5
SCTS-40C	8.0	16.0	3800	9.0x10 <sup>-5</sup>	0.20	2	± 0.5
SCTS-50C	15.0	30.0	3100	2.8x10 <sup>-4</sup>	0.20	2	± 0.5
SCTS-63C	35.0	70.0	2400	8.8x10 <sup>-4</sup>	0.20	2	± 0.5

SCT-C.SCTS-C 標準孔徑 | Stock Bores

單位 / Unit:mm

Catalog Number 型號	Stock Bores 標準孔徑 d1xd2(公差H7)													
	2	3	4	5	6	6.35	8	9.525	10	12	14	15	16	18
SCT - 12C		●	●	●										
SCTS - 12C		●	●	●										
SCT - 16C			●	●	●	●								
SCTS - 16C			●	●	●	●								
SCT - 20C			●	●	●	●	●							
SCTS - 20C				●	●	●	●							
SCT - 25C				●	●	●	●	●	●					
SCTS - 25C					●	●	●	●	●					
SCT - 32C							●		●	●	●			
SCTS - 32C							●		●	●	●			
SCT - 40C							●		●	●	●	●	●	
SCTS - 40C							●		●	●	●	●	●	
SCT - 50C										●	●	●	●	●
SCTS - 50C										●	●	●	●	●
SCT - 63C											●	●	●	●
SCTS - 63C											●	●	●	●

# SWS 開縫型 / 止付螺絲固定式 / 短型撓性聯軸器

## SWSS SLITTED / SET SCREW TYPE / SHORTER OF FLEXIBLE COUPLING



### 材質 | Material

SWS 系列-鋁合金 Aluminum alloy  
SWSS 系列-不銹鋼 Stainless steel

### 表面處理 | Surface Treatment

SWS-陽極處理 Anodizing standard white

### 特性 | Features

1. 一體成型、小巧
  2. 零背隙
  3. 剛性大
  4. 適合譯碼器、小馬力傳動機構、高精度傳動上
  5. 偏角誤差較佳
  6. 不銹鋼材質扭力較佳
  7. 固定方式: 止付螺絲固定式
- Little and One-body shape
  - Zero backlash
  - High rigid
  - Suitable for encoder · low horsepower transmission bodies and high precision transmission mechanism.
  - High deflection
  - Torque in SUS is better
  - Fixed mode: Set screw type

### 型號表示 | Product NO

**SWS-20-**  $\phi 6 \times \phi 6$   
 型號 / Type      孔徑 / Inside dia

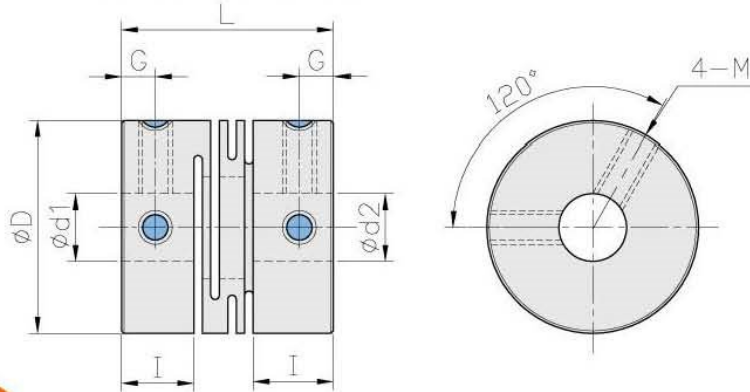

### 尺寸 | Dimension

單位 / Unit:mm

Catalog Number 型號	D	I	L	G	M	d1xd2 標準孔徑 (H7)		Mass** 重量 (g)
						Min	Max	
SWS-16	16	6.8	18	3	M3	4	6	7.4
SWS-20	20	7.65	20	3	M4	5	10	12
SWS-25	25	9.6	25	4	M4	6	12	24
SWS-32	32	12.6	32	6	M5	6	14	50
SWS-40	40	15.3	40	7.5	M5	10	16	115
SWSS-16	16	6.8	18	3	M3	5	6	18
SWSS-20	20	7.65	20	3	M4	5	10	32
SWSS-25	25	9.6	25	4	M4	6	12	63
SWSS-32	32	12.6	32	6	M5	6	14	130

### 性能 | Specifications

單位 / Unit:mm

Catalog Number 型號	Rated Torque 一般扭力 (N.m)	Max. Torque 最大扭力 (N.m)	Max Rotational Frequency 最高回轉速 (Rpm/min)	Moment*of Inertia 慣性 (Kg · m <sup>2</sup> )	Errors of Angularity 容許偏角 (°)	Errors of Shaft End-Play 容許軸向位差 (mm)
SWS-16	0.3	0.6	24000	2.8x10 <sup>-7</sup>	1	±0.2
SWS-20	0.5	1	19000	7.5x10 <sup>-7</sup>	1	±0.2
SWS-25	1	2	15000	2.3x10 <sup>-6</sup>	1	±0.2
SWS-32	2	4	12000	8.0x10 <sup>-6</sup>	1	±0.2
SWS-40	5	10	9800	3.0x10 <sup>-5</sup>	1	±0.2
SWSS-16	0.5	1	24000	7.2x10 <sup>-7</sup>	1	±0.1
SWSS-20	1	2	19000	2.0x10 <sup>-6</sup>	1	±0.1
SWSS-25	2	4	15000	6.1x10 <sup>-6</sup>	1	±0.2
SWSS-32	3.5	7	12000	2.1x10 <sup>-5</sup>	1	±0.2

# SWS-C 開縫型/夾緊式/止付螺絲固定式/短型撓性聯軸器

## SWSS-C SLITTED / SET SCREWTYPE / SHORTER of FLEXIBLE COUPLING



SWS-C

SWSS-C

### 材質 | Material

SWS 系列-鋁合金 Aluminum alloy  
SWSS 系列-不銹鋼 Stainless steel

### 表面處理 | Surface Treatment

SWS-C 陽極處理 Anodizing standard white

### 特性 | Features

- |  |  |
|--|--|
| <ol style="list-style-type: none"> <li>1. 一體成型、小巧</li> <li>2. 零背隙</li> <li>3. 剛性大</li> <li>4. 適合譯碼器、小馬力傳動機構、高精密傳動上</li> <li>5. 偏角誤差較佳</li> <li>6. 不銹鋼材質扭力較佳</li> <li>7. 不銹鋼材質較適用於無塵室</li> <li>8. 固定方式：夾緊式</li> </ol> | <ul style="list-style-type: none"> <li>• Little and One-body shape</li> <li>• Zero backlash</li> <li>• High rigid</li> <li>• Suitable for encoder、low horsepower transmission bodies and high precision transmission mechanism.</li> <li>• High deflection</li> <li>• Torque in SUS is better.</li> <li>• SUS is suitable</li> <li>• Fixed mode: Clamp type</li> </ul> |
|--|--|

### 型號表示 | Product NO

**SWS-20C- $\phi 6 \times \phi 6$**

型號 / Type

孔徑 / Inside dia

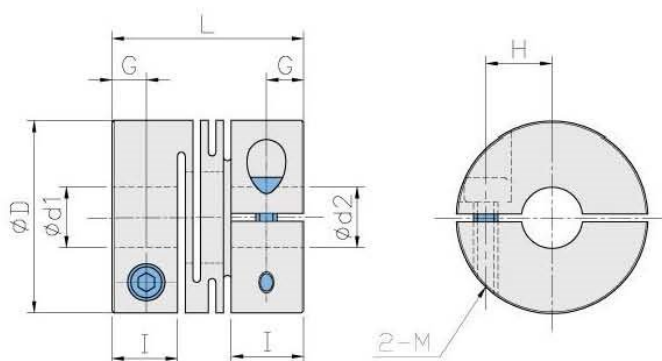

### 尺寸 | Dimension

單位 / Unit:mm

Catalog Number 型號	D	I	L	G	H	M	d1xd2 標準孔徑 (H7)		Mass** 重量 (g)
							Min	Max	
SWS-16C	16	6.8	18	3.4	5	M2.5	4	6	8
SWS-20C	20	7.65	20	3.8	6.5	M3	5	8	13
SWS-25C	25	9	25	4.8	9	M3	6	10	25
SWS-32C	32	12.6	32	6.3	11	M4	6	14	53
SWS-40C	40	15.3	40	7.5	14	M5	10	16	117
SWSS-16C	16	6.8	18	3.4	5	M2.5	5	6	21
SWSS-20C	20	7.65	20	3.8	6.5	M3	5	8	36
SWSS-25C	25	9.6	25	4.8	9	M3	6	10	69
SWSS-32C	32	12.6	32	6.3	11	M4	8	14	150

### 性能 | Specifications

單位 / Unit:mm

Catalog Number 型號	Rated Torque 一般扭力 (N.m)	Max. Torque 最大扭力 (N.m)	Max Rotational Frequency 最高回轉速 (Rpm/min)	Moment*of Inertia 慣性 (Kg · m <sup>2</sup> )	Errors of Angularity 容許偏角 (°)	Errors of Shaft End-Play 容許軸向位差 (mm)
SWS-16C	0.3	0.6	9500	2.9x10 <sup>-7</sup>	1	±0.2
SWS-20C	0.5	1.0	7600	7.5x10 <sup>-7</sup>	1	±0.2
SWS-25C	1.0	2.0	6100	2.3x10 <sup>-6</sup>	1	±0.2
SWS-32C	2.2	4.0	4800	8.1x10 <sup>-6</sup>	1	±0.2
SWS-40C	5.0	10.0	3800	1.9x10 <sup>-5</sup>	1	±0.2
SWSS-16C	0.5	1.0	9500	7.8x10 <sup>-7</sup>	1	±0.2
SWSS-20C	1.0	2.0	7600	2.1x10 <sup>-6</sup>	1	±0.2
SWSS-25C	2.0	4.0	6100	6.3x10 <sup>-6</sup>	1	±0.2
SWSS-32C	3.5	7.0	4800	2.2x10 <sup>-5</sup>	1	±0.2

# SCP 開縫型 / 止付螺絲固定式 / 塑膠撓性聯軸器

SLITTED / PLASIC FLEXIBLE COUPLING



## 材質 | Material

塑膠 Plastic (黑、白 / black&white)

## 型號表示 | Product NO

**SCP-20- $\phi 6 \times \phi 6$**

型號 / Type      孔徑 / Inside dia

## 特性 | Features

- |  |   |
|--|---|
| <ol style="list-style-type: none"> <li>1. 一體成型</li> <li>2. 零背隙</li> <li>3. 耐酸鹼</li> <li>4. 絕緣佳</li> <li>5. 偏角誤差較佳</li> <li>6. 適合用於譯碼器</li> <li>7. 溫度環境適用於70°C內。</li> <li>8. 固定方式: 止付螺絲固定式</li> </ol> | <ul style="list-style-type: none"> <li>• One-body shape</li> <li>• Zero backlash</li> <li>• Acid-alkali resistance</li> <li>• Great insulation</li> <li>• High deflection</li> <li>• Suitable for encoder</li> <li>• The workable temperatures within 70°C</li> <li>• Fixed mode : Set screw type.</li> </ul> |
|--|---|

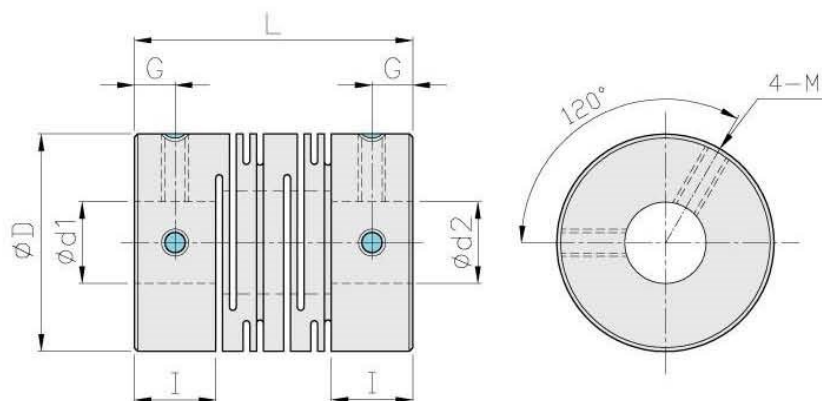

## 尺寸 | Dimension

單位 / Unit:mm

Catalog Number 型號	D	I	L	G	M	d1xd2 標準孔徑 (H7)		Mass** 重量 (g)
						Min	Max	
SCP-16	16	6.5	23	3	M3	5	8	5
SCP-20	20	7.5	26	3.5	M4	6	8	8
SCP-25	25	8.5	31	4	M4	6	12	15

## 性能 | Specifications

單位 / Unit:mm

Catalog Number 型號	Rated Torque 一般扭力 (N.m)	Max. Torque 最大扭力 (N.m)	Max Rotational Frequency 最高回轉速 (Rpm/min)	Moment* of Inertia 慣性 (Kg · m <sup>2</sup> )	Errors of Eccentricity 容許偏心 (mm)	Errors of Angularity 容許偏角 (°)	Errors of Shaft End-Play 容許軸向位差 (mm)
SCP-16	0.15	0.3	6000	1.3x10 <sup>-7</sup>	0.2	2.5	± 0.3
SCP-20	0.25	0.5	8000	4.0x10 <sup>-7</sup>	0.2	2.5	± 0.3
SCP-25	0.5	1.0	10000	10.0x10 <sup>-7</sup>	0.2	2.5	± 0.3

# SMT 螺旋型 / 止付螺絲固定式 / 撓性聯軸器

SHAPED SPIRALLY / SET SCREW TYPE / FLEXIBLE COUPLING



## 材質 | Material

鋁合金 Aluminum alloy

## 表面處理 | Surface Treatment

陽極處理 Anodizing standard white

## 特性 | Features

1. 一體成型
2. 零背隙
3. 螺旋式溝槽，可撓性特佳
4. 最適合譯馬器
5. 固定方式：止付螺絲固定式

- One-body shape
- Zero backlash
- Spiral groove, great flexible performance
- Suitable for encoder
- Fixed mode: Set screw type

## 型號表示 | Product NO

**SMT-20-**  $\phi 6 \times \phi 6$   
 型號/Type 孔徑/Inside dia

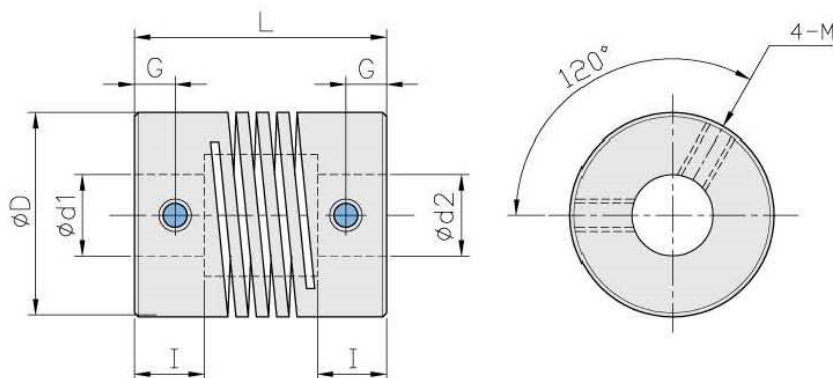

## 尺寸 | Dimension

單位 / Unit:mm

Catalog Number 型號	D	I	L	G	M	d1xd2 標準孔徑 (H7)		Mass** 重量 (g)
						Min	Max	
SMT-16	16	7.6	23	3.5	M3	4	8	10
SMT-16S	16	4.3	16	2.5	M3	4	8	8
SMT-19	19	7	23	3	M3	5	8	13
SMT-19S	19	5	19	3	M3	5	8	11
SMT-20	20	8.6	26	3	M4	6	10	15
SMT-25	25	10.6	31	4	M4	6	12	31
SMT-25S	25	7.5	25	4	M4	6	12	29

## 性能 | Specifications

單位 / Unit:mm

Catalog Number 型號	Rated Torque 一般扭力 (N.m)	Max. Torque 最大扭力 (N.m)	Max Rotational Frequency 最高回轉速 (Rpm/min)	Moment* of Inertia 慣性 (Kg · m <sup>2</sup> )	Errors of Eccentricity 容許偏心 (mm)	Errors of Angularity 容許偏角 (°)
SMT-16	0.5	1.0	25000	± 0.25	0.25	5
SMT-16S	0.5	1.0	25000	± 0.25	0.25	5
SMT-19	1.0	2.0	25000	± 0.25	0.25	5
SMT-19S	1.0	2.0	25000	± 0.25	0.25	5
SMT-20	1.1	2.2	25000	± 0.25	0.25	5
SMT-25	1.6	3.2	25000	± 0.25	0.25	5
SMT-25S	1.6	3.2	25000	± 0.25	0.25	5

# SMT-C 螺旋型 / 夾緊式 / 撓性聯軸器

SHAPED SPIRALLY / CLAMP TYPE / FLEXIBLE COUPLING



## 材質 | Material

鋁合金 Aluminum alloy

## 表面處理 | Surface Treatment

陽極處理 Anodizing standard white

## 特性 | Features

1. 一體成型
2. 零背隙
3. 螺旋式溝槽，可撓性特佳
4. 最適合譯馬器
5. 固定方式：夾緊式

## 型號表示 | Product NO

**SMT-20C- $\phi 6 \times \phi 6$**

型號 / Type    孔徑 / Inside dia

- One-body shape
- Zero backlash
- Spiral groove, great flexible performance
- Suitable for encoder
- Fixed mode: Clamp type

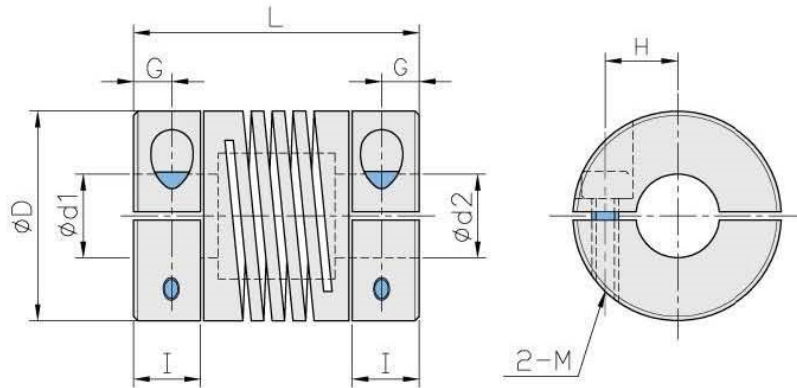

## 尺寸 | Dimension

單位 / Unit:mm

Catalog Number 型號	D	I	L	G	H	M	d1xd2 標準孔徑 (H7)		Mass** 重量 (g)
							Min	Max	
<b>SMT-16C</b>	16	6.2	23	2.5	5.0	M2.5	4	6.35	10
<b>SMT-19C</b>	19	6.5	23	3.0	5.6	M3.0	4	8.0	13
<b>SMT-20C</b>	20	7.5	26	3.0	5.7	M3.0	6	8.0	13
<b>SMT-25C</b>	25	8	31	4.0	7.5	M4.0	6	12.0	31

## 性能 | Specifications

單位 / Unit:mm

Catalog Number 型號	Rated Torque 一般扭力 (N.m)	Max. Torque 最大扭力 (N.m)	Max Rotational Frequency 最高回轉速 (Rpm/min)	Errors of Shaft End-Play 容許軸向位差 (mm)	Errors of Eccentricity 容許偏心 (mm)	Errors of Angularity 容許偏角 (°)
<b>SMT-16C</b>	0.5	1.0	25000	±0.25	0.25	5
<b>SMT-19C</b>	0.5	1.0	25000	±0.25	0.25	5
<b>SMT-20C</b>	0.6	1.2	25000	±0.25	0.25	5
<b>SMT-25C</b>	1.1	2.2	25000	±0.25	0.25	5

# SGH-C 鋼片型 / 夾緊式 / 短型撓性聯軸器

DISK / CLAMP TYPE / SHORTER OF FLEXIBLE COUPLING



### 材質 | Material

鋁合金 Aluminum alloy  
緩衝材: 不銹鋼彈片  
Buffer material: SUS disk

### 表面處理 | Surface Treatment

陽極處理 Anodizing standard white

### 特性 | Features

1. 高剛性
2. 扭力大
3. 低慣性
4. 零背隙
5. 適用於工作母機、伺服馬達、  
高精度傳動
6. 固定方式: 夾緊式

- High rigid
- High torque
- Low inertia
- Zero backlash
- Suitable for working machine、  
servomotor and high precision  
transmission mechanism.
- Fixed mode: Clamp type

### 型號表示 | Product NO

**SGH-50C- $\phi$ 15x $\phi$ 15**

型號 / Type      孔徑 / Inside dia

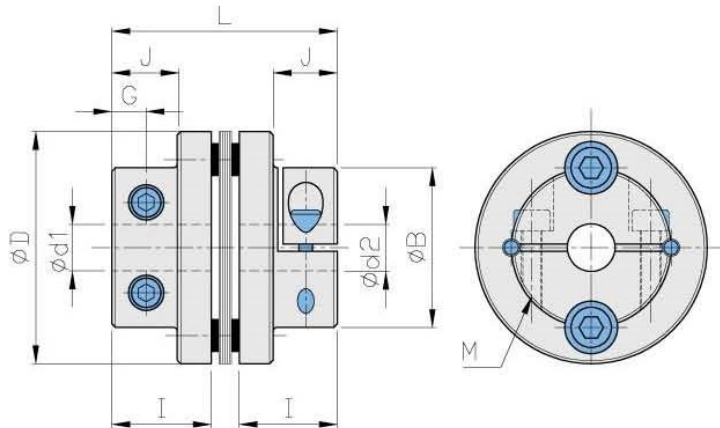

## 尺寸 | Dimension

單位 / Unit:mm

Catalog Number 型號	D	B	J	I	L	G	M	d1xd2 標準孔徑 (H7)		Mass** 重量 (g)
								Min	Max	
SGH-40C	40	28	10.5	15	34.5	4.75	2-M4	8	16	63
SGH-45C	45	33	10.5	15	34.5	4.75	4-M4	10	18	88
SGH-50C	50	40	15	20	46.5	7	4-M5	12	20	120
SGH-57C	57	42	14	20	47	6	4-M5	10	22	175
SGH-65C	65	50	18	24	55	8	4-M6	15	25	200

## 性能 | Specifications

單位 / Unit:mm

Catalog Number 型號	Rated Torque 一般扭力 (N.m)	Max. Torque 最大扭力 (N.m)	Max Rotational Frequency 最高回轉速 (Rpm/min)	Moment* of Inertia 慣性 (Kg · m <sup>2</sup> )	Errors of Shaft End-Play 容許軸向位差 (mm)	Errors of Angularity 容許偏角 (°)
SGH-40C	6	12	10000	9.2x10 <sup>-6</sup>	±0.02	1.0
SGH-45C	9	18	10000	23.2x10 <sup>-6</sup>	±0.02	1.0
SGH-50C	17	34	10000	32.6x10 <sup>-6</sup>	±0.02	1.0
SGH-57C	25	50	10000	51.2x10 <sup>-6</sup>	±0.02	1.0
SGH-65C	55	110	10000	127.4x10 <sup>-6</sup>	±0.02	1.0



# SGS-C 鋼片型 / 夾緊式 / 短型撓性聯軸器

DISK / CLAMP TYPE / SHORTER OF FLEXIBLE COUPLING



## 材質 | Material

鋁合金 Aluminum alloy  
緩衝材: 不銹鋼彈片  
Buffer material: SUS disk

## 表面處理 | Surface Treatment

陽極處理 Anodizing standard white

## 特性 | Features

1. 高剛性
  2. 扭力大
  3. 低慣性
  4. 零背隙
  5. 適用於工作母機、伺服馬達、高精密傳動
  6. 固定方式: 夾緊式
- High rigid
  - High torque
  - Low inertia
  - Zero backlash
  - Suitable for working machine, servomotor and high precision transmission mechanism.
  - Fixed mode: Clamp type

## 型號表示 | Product NO

**SGS-27C- $\phi 6 \times \phi 6$**

型號 / Type      孔徑 / Inside dia

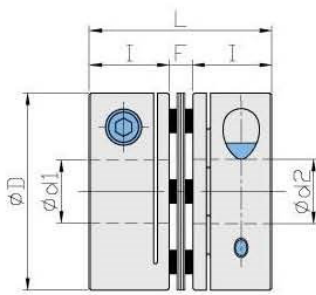

外徑  $\phi 27 \sim \phi 34$

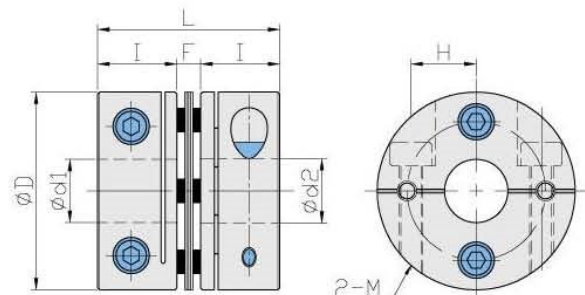

外徑  $\phi 40 \sim \phi 65$

## 尺寸 | Dimension

單位 / Unit: mm

Catalog Number 型號	D	I	F	L	H	M	d1xd2 標準孔徑 (H7)		Mass** 重量 (g)
							Min	Max	
SGS-27C	27	10.5	2.5	23.5	9.0	M3	5	10	30
SGS-34C	34	12.0	3.0	27.0	12.0	M3	6	14	48
SGS-40C	40	15.0	4.5	34.5	14.0	M4	8	16	93
SGS-45C	45	15.0	5.0	34.5	16.0	M4	10	19	110
SGS-50C	50	20.0	6.0	46.0	18.0	M5	10	22	215
SGS-57C	57	20.0	6.0	46.0	21.0	M5	12	25	240
SGS-65C	65	24.0	7.0	55.0	25.0	M6	12	28	445

## 性能 | Specifications

單位 / Unit: mm

Catalog Number 型號	Rated Torque 一般扭力 (N.m)	Max. Torque 最大扭力 (N.m)	Max Rotational Frequency 最高回轉速 (Rpm/min)	Moment* of Inertia 慣性 (Kg · m <sup>2</sup> )	Errors of Eccentricity 容許偏心 (mm)	Errors of Shaft End-Play 容許軸向位差 (mm)	Errors of Angularity 容許偏角 (°)
SGS-27C	1.5	3	10000	2.5x10 <sup>-6</sup>	0.02	± 0.15	1.0
SGS-34C	6	12	10000	8.2x10 <sup>-6</sup>	0.02	± 0.20	1.0
SGS-40C	7	14	10000	19.0x10 <sup>-6</sup>	0.02	± 0.25	1.0
SGS-45C	10	20	10000	29.7x10 <sup>-6</sup>	0.02	± 0.30	1.0
SGS-50C	17	34	10000	75.0x10 <sup>-6</sup>	0.02	± 0.30	1.0
SGS-57C	25	50	10000	100.0x10 <sup>-6</sup>	0.02	± 0.40	1.0
SGS-65C	25	110	10000	250.0x10 <sup>-6</sup>	0.02	± 0.40	1.0

# SGL-C 鋼片型 / 夾緊式 / 撓性聯軸器

DISK / CLAMP TYPE / FLEXIBLE COUPLING



## 材質 | Material

鋁合金 Aluminum alloy  
緩衝材: 不銹鋼彈片  
Buffer material: SUS disk

## 表面處理 | Surface Treatment

陽極處理 Anodizing standard white

## 特性 | Features

- |   |   |
|---|---|
| <ol style="list-style-type: none"> <li>1. 扭力大</li> <li>2. 偏角誤差較佳</li> <li>3. 低慣性</li> <li>4. 零背隙</li> <li>5. 適用於工作母機、伺服馬達、<br/>高精密傳動</li> <li>6. 固定方式: 夾緊式</li> </ol> | <ul style="list-style-type: none"> <li>• High torque</li> <li>• High deflection</li> <li>• Low inertia</li> <li>• Zero backlash</li> <li>• Suitable for working machine、<br/>servomotor and high precision<br/>transmission mechanism.</li> <li>• Fixed mode: Clamp type</li> </ul> |
|---|---|

## 型號表示 | Product NO

**SGL-40C- $\phi 8 \times \phi 8$**

型號 / Type      孔徑 / Inside dia

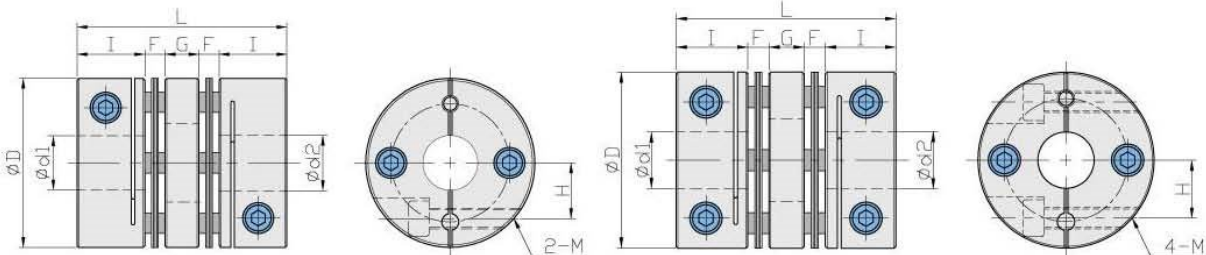

外徑  $\phi 27 \sim \phi 34$

外徑  $\phi 40 \sim \phi 65$

## 尺寸 | Dimension

單位 / Unit: mm

Catalog Number 型號	D	I	F	G	L	H	M	d1xd2 標準孔徑 (H7)		Mass** 重量 (g)
								Min	Max	
<b>SGL-27C</b>	27	10.5	2.5	6	32	9.0	2-M3	5	10	39
<b>SGL-34C</b>	34	12.0	3.0	7.5	37.5	12.0	2-M3	6	14	70
<b>SGL-40C</b>	40	15.0	4.5	9	48	13.5	4-M4	8	16	128
<b>SGL-45C</b>	45	15.0	4.5	9	48	16.0	4-M4	10	19	140
<b>SGL-50C</b>	50	20.0	6.0	11	63	18.0	4-M5	10	22	285
<b>SGL-57C</b>	57	20.0	6.0	11	63	21.0	4-M5	12	25	310
<b>SGL-65C</b>	65	24.0	7.0	14	76	23.0	4-M6	12	28	570

## 性能 | Specifications

單位 / Unit: mm

Catalog Number 型號	Rated Torque 一般扭力 (N.m)	Max. Torque 最大扭力 (N.m)	Max Rotational Frequency 最高回轉速 (Rpm/min)	Moment* of Inertia 慣性 (Kg · m <sup>2</sup> )	Errors of Eccentricity 容許偏心 (mm)	Errors of Shaft End-Play 容許軸向位差 (mm)	Errors of Angularity 容許偏角 (°)
<b>SGL-27C</b>	1.5	3	10000	$3.0 \times 10^{-6}$	0.15	$\pm 0.33$	1.5
<b>SGL-34C</b>	3	6	10000	$10.5 \times 10^{-6}$	0.17	$\pm 0.4$	1.5
<b>SGL-40C</b>	7	14	10000	$26.4 \times 10^{-6}$	0.23	$\pm 0.5$	1.5
<b>SGL-45C</b>	10	20	10000	$41.7 \times 10^{-6}$	0.23	$\pm 0.6$	1.5
<b>SGL-50C</b>	17	34	10000	$135.0 \times 10^{-6}$	0.23	$\pm 0.8$	1.5
<b>SGL-57C</b>	25	50	10000	$144.0 \times 10^{-6}$	0.23	$\pm 0.8$	1.5
<b>SGL-65C</b>	55	110	10000	$360.0 \times 10^{-6}$	0.28	$\pm 0.9$	1.5

# SGB-C 鋼片型 / 夾緊式 / 短型撓性聯軸器

DISK / CLAMP TYPE / SHORTER OF FLEXIBLE COUPLING



## 材質 | Material

鋁合金 Aluminum alloy  
緩衝材: 不銹鋼彈片  
Buffer material: SUS disk

## 表面處理 | Surface Treatment

陽極處理 Anodizing standard white

## 特性 | Features

1. 高剛性
2. 扭力大
3. 低慣性
4. 零背隙
5. 適用於工作母機、伺服馬達、  
高精度傳動
6. 固定方式: 夾緊式

## 型號表示 | Product NO

**SGB-50C- $\phi$ 20x $\phi$ 20**

型號 / Type      孔徑 / Inside dia

- High rigid
- High torque
- Low inertia
- Zero backlash
- Suitable for working machine、  
servomotor and high precision  
transmission mechanism.
- Fixed mode: Clamp type

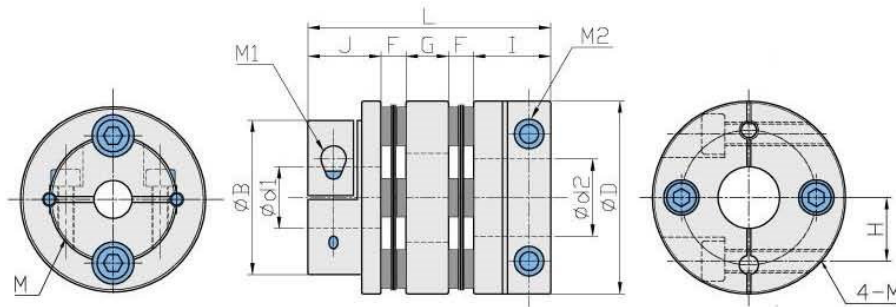

## 尺寸 | Dimension

單位 / Unit:mm

Catalog Number 型號	D	B	I	F	L	M	d1xd2 標準孔徑 (H7)		Mass** 重量 (g)
							Min	Max	
<b>SGB-40C</b>	40	28	15	4.5	34.5	3-M4	8	16	88
<b>SGB-45C</b>	45	33	15	4.5	34.5	3-M4	8	18	100
<b>SGB-50C</b>	50	40	20	6.0	46	4-M5	10	20	188
<b>SGB-57C</b>	57	42	20	6.0	46	4-M5	12	25	205
<b>SGB-65C</b>	65	50	24	7.0	55	4-M6	12	28	368

## 性能 | Specifications

單位 / Unit:mm

Catalog Number 型號	Rated Torque 一般扭力 (N.m)	Max. Torque 最大扭力 (N.m)	Max Rotational Frequency 最高回轉速 (Rpm/min)	Moment* of Inertia 慣性 (Kg · m <sup>2</sup> )	Errors of Eccentricity 容許偏心 (mm)	Errors of Shaft End-Play 容許軸向位差 (mm)	Errors of Angularity 容許偏角 (°)
<b>SGB-40C</b>	6	12	10000	17x10 <sup>-6</sup>	0.02	± 0.25	1.0
<b>SGB-45C</b>	9	18	10000	23x10 <sup>-6</sup>	0.02	± 0.30	1.0
<b>SGB-50C</b>	17	34	10000	48x10 <sup>-6</sup>	0.02	± 0.30	1.0
<b>SGB-57C</b>	25	50	10000	76x10 <sup>-6</sup>	0.02	± 0.40	1.0
<b>SGB-65C</b>	55	110	10000	185x10 <sup>-6</sup>	0.02	± 0.40	1.0

# SGM-C 鋼片型 / 夾緊式 / 撓性聯軸器

DISK / CLAMP TYPE / FLEXIBLE COUPLING



## 材質 | Material

鋁合金 Aluminum alloy  
緩衝材: 不銹鋼彈片  
Buffer material: SUS disk

## 表面處理 | Surface Treatment

陽極處理 Anodizing standard white

## 特性 | Features

1. 扭力大
  2. 偏角誤差較佳
  3. 低慣性
  4. 零背隙
  5. 適用於工作母機、伺服馬達、高精密傳動
  6. 固定方式: 夾緊式
- High torque
  - High deflection
  - Low inertia
  - Zero backlash
  - Suitable for working machine、servomotor and high precision transmission mechanism.
  - Fixed mode: Clamp type

## 型號表示 | Product NO

**SGM-50C- $\phi$ 20x $\phi$ 20**

型號 / Type      孔徑 / Inside dia

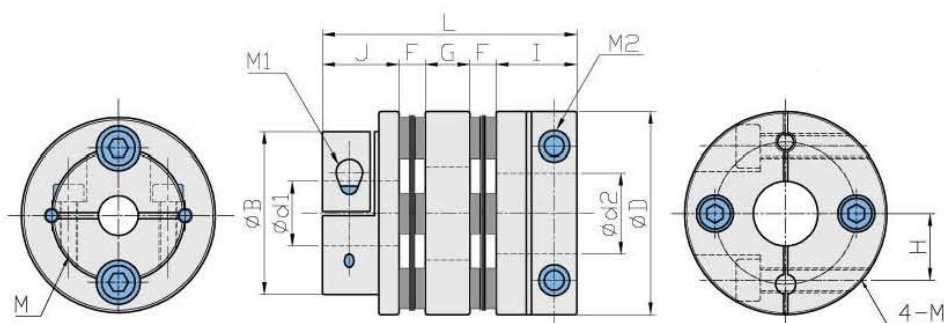

## 尺寸 | Dimension

單位 / Unit:mm

Catalog Number 型號	D	B	J	F	G	I	L	M1	M2	d1xd2 標準孔徑 (H7)		Mass** 重量 (g)
										Min	Max	
<b>SGM-40C</b>	40	28	15	4.5	9	15	48	1-M4	2-M4	8	16	121
<b>SGM-45C</b>	45	33	15	4.5	9	15	48	2-M4	2-M4	8	18	130
<b>SGM-50C</b>	50	40	20	6	11	20	63	2-M5	2-M5	10	20	250
<b>SGM-57C</b>	57	42	20	6	11	20	63	2-M5	2-M5	12	25	270
<b>SGM-65C</b>	65	50	24	7	14	24	76	2-M6	2-M6	12	28	550

## 性能 | Specifications

單位 / Unit:mm

Catalog Number 型號	Rated Torque 一般扭力 (N.m)	Max. Torque 最大扭力 (N.m)	Max Rotational Frequency 最高回轉速 (Rpm/min)	Moment* of Inertia 慣性 (Kg · m <sup>2</sup> )	Errors of Eccentricity 容許偏心 (mm)	Errors of Shaft End-Play 容許軸向位差 (mm)	Errors of Angularity 容許偏角 (°)
<b>SGM-40C</b>	6	12	10000	20.5x10 <sup>-6</sup>	0.2	±0.6	1.5
<b>SGM-45C</b>	9	18	10000	35.1x10 <sup>-6</sup>	0.2	±0.6	1.5
<b>SGM-50C</b>	17	34	10000	73.3x10 <sup>-6</sup>	0.2	±0.8	1.5
<b>SGM-57C</b>	25	50	10000	112.3x10 <sup>-6</sup>	0.25	±0.8	1.5
<b>SGM-65C</b>	55	110	10000	286.1x10 <sup>-6</sup>	0.3	±0.9	1.5

# SGW-C 鋼片型 / 夾緊式 / 撓性聯軸器

DISK / CLAMP TYPE / FLEXIBLE COUPLER



## 材質 | Material

鋁合金 Aluminum alloy  
緩衝材: 不銹鋼彈片  
Buffer material: SUS disk

## 表面處理 | Surface Treatment

陽極處理 Anodizing standard white

## 特性 | Features

1. 扭力大
2. 偏角誤差較佳
3. 低慣性
4. 零背隙
5. 適用於工作母機、伺服馬達、高精密傳動
6. 固定方式: 夾緊式

## 型號表示 | Product NO

**SGW-50C- $\phi$ 20x $\phi$ 20**

型號 / Type

孔徑 / Inside dia

- High torque
- High deflection
- Low inertia
- Zero backlash
- Suitable for working machine, servomotor and high precision transmission mechanism.
- Fixed mode: Clamp type

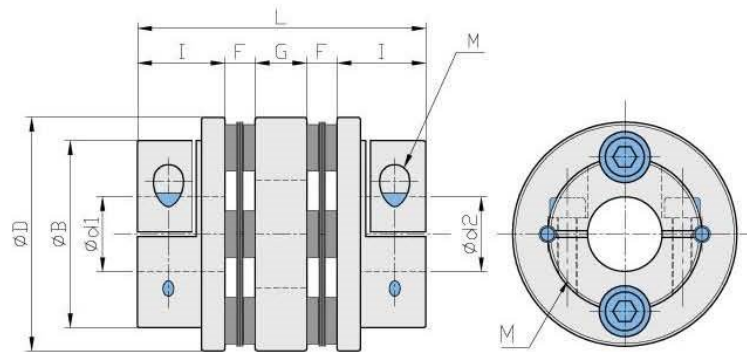

## 尺寸 | Dimension

單位 / Unit:mm

Catalog Number 型號	D	B	I	F	G	L	M	d1xd2 標準孔徑 (H7)		Mass** 重量 (g)
								Min	Max	
SGW-40C	40	28	15	4.5	9	48	3-M4	8	16	100
SGW-45C	45	33	15	4.5	9	48	4-M4	10	18	120
SGW-50C	50	40	20	6.5	11	64	4-M5	10	20	230
SGW-57C	57	42	20	6.5	11	64	4-M5	10	22	248
SGW-65C	65	50	24	7.0	14	76	4-M6	12	28	540

## 性能 | Specifications

單位 / Unit:mm

Catalog Number 型號	Rated Torque 一般扭力 (N.m)	Max. Torque 最大扭力 (N.m)	Max Rotational Frequency 最高回轉速 (Rpm/min)	Moment* of Inertia 慣性 (Kg · m <sup>2</sup> )	Errors of Eccentricity 容許偏心 (mm)	Errors of Shaft End-Play 容許軸向位差 (mm)	Errors of Angularity 容許偏角 (°)
SGW-40C	6	12	10000	15.3x10 <sup>-6</sup>	0.2	±0.6	1.5
SGW-45C	9	18	10000	28.2x10 <sup>-6</sup>	0.2	±0.6	1.5
SGW-50C	17	34	10000	53.6x10 <sup>-6</sup>	0.2	±0.8	1.5
SGW-57C	25	50	10000	87.1x10 <sup>-6</sup>	0.25	±0.8	1.5
SGW-65C	55	110	10000	225.9x10 <sup>-6</sup>	0.3	±0.9	1.5

# SAP 止付螺絲固定式 / 剛片式撓性聯軸器

SET / SCREW TYPE / DISK FLEXIBLE COUPLING



## 材質 | Material

鋼 S45C  
緩衝材: 不銹鋼彈片  
Buffer material: SUS disk

## 表面處理 | Surface Treatment

染黑 Dye black

## 特性 | Features

1. 高扭力、高剛性
2. 低慣性、零背隙
3. 適合用於中大型伺服馬達
4. 固定方式: 止付螺絲固定式
5. 一般皆含鍵槽加工使之固定

型號表示 | Product NO

**SAP-82- $\varnothing$ 20x $\varnothing$ 20**

型號/Type    孔徑/Inside dia

- High torque - high rigid.
- Low inertia - zero backlash
- Applicable to large and medium servo motors
- Fixed mode: Set screw type
- Containing keyway processing for fixing

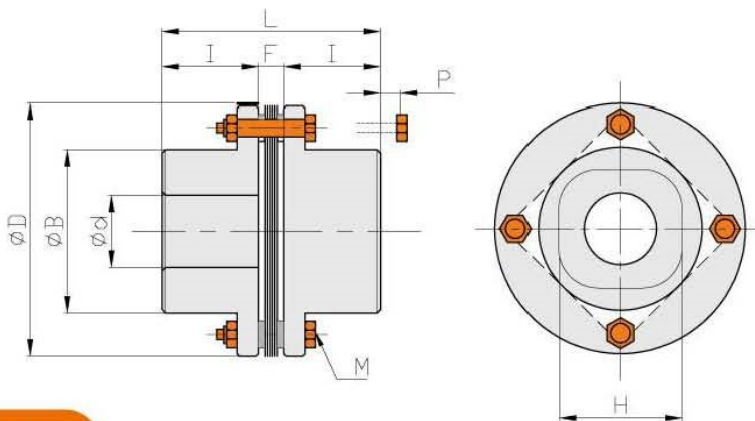

## 尺寸 | Dimension

單位 / Unit:mm

Catalog Number 型號	D	B	d		L	I	F	H	M	P
			Min	Max						
SAP-68	68	40	10	25	56	25	6	28	4-M6	13
SAP-82	82	54	12	35	56.2	25	6.2	34	4-M6	13
SAP-94	94	58	12	38	69.6	30	9.6	40	4-M8	23
SAP-104	104	68	20	45	76	33	10	42	4-M8	20
SAP-126	126	78	20	50	91	40	11	50	4-M10	25
SAP-144	144	88	20	60	102	45	12	57	4-M10	20
SAP-168	168	104	30	70	164	75	14	108	6-M10	
SAP-180	180	120	30	85	176	80	16	115	6-M10	
SAP-215	215	128	40	90	200	90	20	128	6-M16	

## 性能 | Specifications

單位 / Unit:mm

Catalog Number 型號	Rated Torque 一般扭力 (N.m)	Max. Torque 最大扭力 (N.m)	Max Rotational Frequency 最高回轉速 (Rpm/min)	Moment* of Inertia 慣性 (Kg · m <sup>2</sup> )	Errors of Shaft End-Play 容許軸向位差 (mm)	Errors of Angularity 容許偏角 (°)
SAP-68	40	80	20000	3	±0.8	1
SAP-82	80	160	17000	8.7	±1.0	1
SAP-94	180	360	15000	16	±1.2	1
SAP-104	245	490	13000	26	±1.4	1
SAP-126	441	882	11000	65	±1.6	1
SAP-144	780	1560	9000	99	±1.8	1
SAP-168	1170	2340	5100	238	±1.0	1
SAP-180	1960	3920	4800	365	±1.0	1
SAP-215	4903	9806	4300	830	±1.0	1

# SAP-C C型襯套迫緊環固定式 / 鋼片式撓性聯軸器

Fixed By Free-button Compression Ring / Disk Flexible Coupling



## 材質 | Material

鋼 S45C  
緩衝材: 不銹鋼彈片  
Buffer material: SUS disk

## 表面處理 | Surface Treatment

染黑 Dye black

## 特性 | Features

1. 高扭力、高剛性
2. 低慣性、零背隙
3. 適合用於中大型伺服馬達
4. 固定方式: 免鍵軸環固定式

## 型號表示 | Product NO

**SAP-82C- $\phi$ 20x $\phi$ 20**

型號 / Type      孔徑 / Inside dia

- High torque · high rigid.
- Low inertia · zero backlash
- Applicable to large and medium servo motors
- Fixed mode: Fixed by free-button compression ring

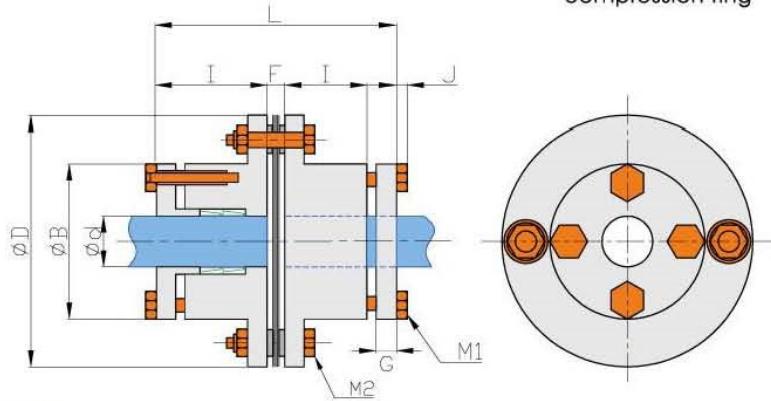

## 尺寸 | Dimension

單位 / Unit:mm

Catalog Number 型號	D	B	d		L	I	F	G	J	M1	M2
			Min	Max							
SAP-68C	68	40	10	18	76	25	6	7	5	M6x4	M6
SAP-82C	82	54	14	30	76.2	25	6.2	7	5	M6x4	M6
SAP-94C	94	58	14	35	89.6	30	9.6	7	5	M6x4	M8
SAP-104C	104	68	20	42	98	33	10	8	5	M6x6	M8
SAP-126C	126	78	25	50	117	40	11	10	7	M8x4	M10
SAP-144C	144	88	30	55	128	45	12	10	7	M8x4	M10
SAP-168C	168	104	35	65	200	75	14	15	7	M8x6	M10
SAP-180C	180	120	35	75	212	80	16	15	7	M8x6	M10
SAP-215C	215	128	40	85	242	90	20	18	8	M10x6	M16

## 性能 | Specifications

單位 / Unit:mm

Catalog Number 型號	Rated Torque 一般扭力 (N.m)	Max. Torque 最大扭力 (N.m)	Max Rotational Frequency 最高回轉速 (Rpm/min)	Moment* of Inertia 慣性 (Kg · m <sup>2</sup> )	Errors of Shaft End-Play 容許軸向位差 (mm)	Errors of Angularity 容許偏角 (°)
SAP-68C	39	78	20000	3.0	±0.8	1
SAP-82C	78	156	17000	8.7	±1.0	1
SAP-94C	176	352	15000	16	±1.2	1
SAP-104C	245	490	13000	26	±1.4	1
SAP-126C	440	880	11000	65	±1.6	1
SAP-144C	780	1560	9000	99	±1.8	1
SAP-168C	1170	2340	5100	238	±1.0	1
SAP-180C	1960	3920	4800	365	±1.0	1
SAP-215C	4900	9800	4300	830	±1.0	1

# SRJ

## 爪型 / 止付螺絲固定式 / 撓性聯軸器

### JAW / SET SCREW TYPE / FLEXIBLE COUPLING



#### 材質 | Material

鋁合金 Aluminum alloy  
 緩衝材: PU (紅色硬度95Sh A)  
 Buffer material : PU  
 (hardness : red/95 Sh A)

#### 型號表示 | Product NO

**SRJ-20-RD- $\phi 6 \times \phi 6$** 

型號 / Type

孔徑 / Inside dia

#### 表面處理 | Surface Treatment

陽極處理 Anodizing standard white

#### 特性 | Features

- |                          |   |
|--------------------------|---|
| 1. 高扭力                   | • High torque   |
| 2. 高剛性                   | • High rigid  |
| 3. 抗震佳                   | • Great shock resistance  |
| 4. 適合用於一般傳動機構、慣性較大及切削機構。 | • Suitable for general transmission、high inertia and cutting mechanism. |
| 5. 適用溫度環境 -30°C~80°C     | • Operating temperatures: -30°C~80°C                                    |
| 6. 固定方式: 止付螺絲固定式         | • Fixed mode: Set screw type  |

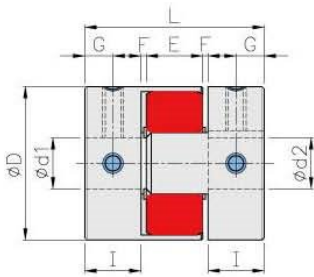
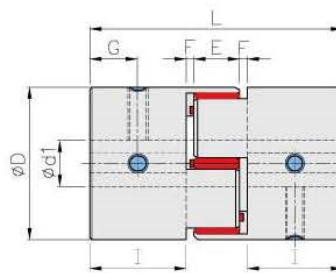
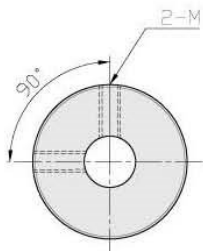
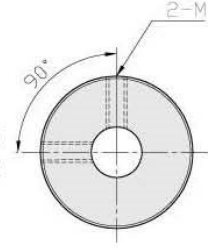
外徑  $\phi 20 \sim \phi 30$ 外徑  $\phi 40 \sim \phi 65$ 

#### 尺寸 | Dimension

單位 / Unit:mm

Catalog Number 型號	D	I	L	E	F	G	M	d1xd2 標準孔徑 (H7)		Mass** 重量 (g)
								Min	Max	
SRJ-20-RD	20	10	30	9	0.5	5	M3	5	9.525	18
SRJ-30-RD	30	11	35	11	0.5	5.5	M4	6	14	50
SRJ-40-RD	40	25	66	14	1.0	12.5	M5	8	19	190
SRJ-40S-RD	40	14	42	14	1.0	7.0	M5	8	19	170
SRJ-55-RD	55	30	78	16	1.0	10.0	M6	12	25	350
SRJ-65-RD	65	35	90	17.5	1.25	17.5	M8	15	35	570
SRJ-80-RD	80	45	114	21	1.5	22.5	M8	15	45	1400

#### 性能 | Specifications

單位 / Unit:mm

Catalog Number 型號	Rated Torque 一般扭力 (N.m)	Max. Torque 最大扭力 (N.m)	Max Rotational Frequency 最高回轉速 (Rpm/min)	Moment* of Inertia 慣性 (Kg · m <sup>2</sup> )	Errors of Eccentricity 容許偏心 (mm)	Errors of Angularity 容許偏角 (°)	Errors of Shaft End-Play 容許軸向位差 (mm)
SRJ-20-RD	5	10	23000	1.0x10 <sup>-6</sup>	0.10	1.0	± 0.4
SRJ-30-RD	12.5	25	19000	5.8x10 <sup>-6</sup>	0.10	1.0	± 0.5
SRJ-40-RD	17	34	14000	4.0x10 <sup>-5</sup>	0.10	1.0	± 0.6
SRJ-40S-RD	17	34	14000	3.9x10 <sup>-5</sup>	0.10	1.0	± 0.6
SRJ-55-RD	60	120	10500	1.6x10 <sup>-4</sup>	0.10	1.0	± 0.7
SRJ-65-RD	160	320	8500	3.8x10 <sup>-4</sup>	0.10	1.0	± 0.75
SRJ-80-RD	400	900	7100	6.3x10 <sup>-3</sup>	0.10	1.0	± 0.8



# SRJ-C 爪型 / 夾緊式 / 撓性聯軸器

JAW / CLAMP TYPE / FLEXIBLE COUPLING



## 材質 | Material

鋁合金 Aluminum alloy  
緩衝材: PU (紅色硬度95Sh A)  
Buffer material : PU  
(hardness : red/95 Sh A)

## 表面處理 | Surface Treatment

陽極處理 Anodizing standard white

## 特性 | Features

- |  |  |
|--|--|
| <ol style="list-style-type: none"> <li>1. 高扭力</li> <li>2. 高剛性</li> <li>3. 抗震佳</li> <li>4. 適合用於一般傳動機構、慣性較大及切削機構。</li> <li>5. 適用溫度環境 -30°C~80°C</li> <li>6. 固定方式: 夾緊式</li> </ol> | <ul style="list-style-type: none"> <li>• High torque</li> <li>• High rigid</li> <li>• Great shock resistance</li> <li>• Suitable for general transmission、high inertia and cutting mechanism.</li> <li>• Operating temperatures: -30°C~80°C</li> <li>• Fixed mode: clamp type</li> </ul> |
|--|--|

## 型號表示 | Product NO

**SRJ-20C- $\phi$ 6x $\phi$ 6**

型號/Type      孔徑/Inside dia

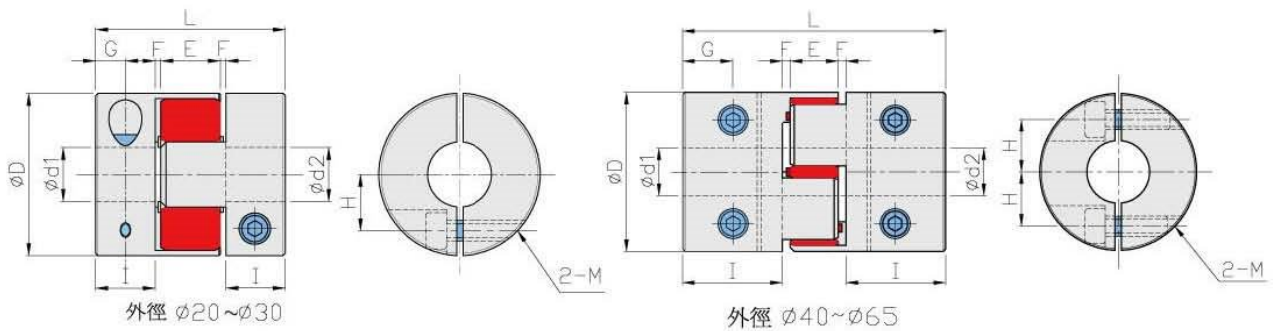

## 尺寸 | Dimension

單位 / Unit:mm

Catalog Number 型號	D	I	L	E	F	G	H	M	$d1 \times d2$ 標準孔徑 (H7)		Mass** 重量 (g)
									Min	Max	
SRJ-20C-RD	20	10	30	9	0.5	5.0	6.5	M2.5	5	8	19
SRJ-30C-RD	30	11	34	11	0.5	5.5	10.0	M4	6	14	50
SRJ-40C-RD	40	25	66	14	1.0	8.5	14.0	M5	10	19	190
SRJ-55C-RD	55	30	78	16	1.0	10.5	20.0	M6	15	25	412
SRJ-65C-RD	65	35	90	17.5	1.25	13.0	24.0	M8	12	35	560
SRJ-80C-RD	80	45	114	21	1.5	15.0	31.0	M8	15	45	1400

## 性能 | Specifications

單位 / Unit:mm

Catalog Number 型號	Rated Torque 一般扭力 (N.m)	Max. Torque 最大扭力 (N.m)	Max Rotational Frequency 最高回轉速 (Rpm/min)	Moment* of Inertia 慣性 (Kg · m <sup>2</sup> )	Errors of Eccentricity 容許偏心 (mm)	Errors of Angularity 容許偏角 ( $^{\circ}$ )	Errors of Shaft End-Play 容許軸向位差 (mm)
SRJ-20C-RD	5.0	10	23000	$1.0 \times 10^{-6}$	0.10	1.0	$\pm 0.4$
SRJ-30C-RD	12.5	25	19000	$6.1 \times 10^{-6}$	0.10	1.0	$\pm 0.5$
SRJ-40C-RD	17.0	34	14000	$3.8 \times 10^{-5}$	0.10	1.0	$\pm 0.6$
SRJ-55C-RD	60.0	120	10500	$1.5 \times 10^{-4}$	0.10	1.0	$\pm 0.7$
SRJ-65C-RD	160.0	320	8500	$3.8 \times 10^{-4}$	0.10	1.0	$\pm 0.75$
SRJ-80C-RD	450.0	900	7100	$6.2 \times 10^{-3}$	0.10	1.0	+ 0.8

# SRJS 爪型 / 止付螺絲固定式 / 撓性聯軸器

JAW / SET SCREW TYPE / FLEXIBLE COUPLING

# SRJS-C 爪型 / 夾緊式 / 撓性聯軸器

JAW / CLAMP TYPE / FLEXIBLE COUPLING



### 材質 | Material

中碳鋼 S45C  
緩衝材: PU (紅色硬度95Sh A)  
Buffer material: PU  
(hardness: red/95 Sh A)

### 型號表示 | Product NO

**SRJS-80-RD- $\phi$ 6x $\phi$ 6**

型號 / Type    孔徑 / Inside dia

### 特性 | Features

1. 高扭力
  2. 高剛性
  3. 抗震佳
  4. 適合用於一般重力傳動機構、慣性較大及切削機構
  5. 適用溫度環境 -30°C~80°C
  6. 固定方式: 止付螺絲固定式
- High torque
  - High rigid
  - Great shock resistance
  - Suitable for general gravity transmission、high inertia and cutting mechanism.
  - Operating temperatures: -30°C~80°C
  - Fixed mode: Set screw type

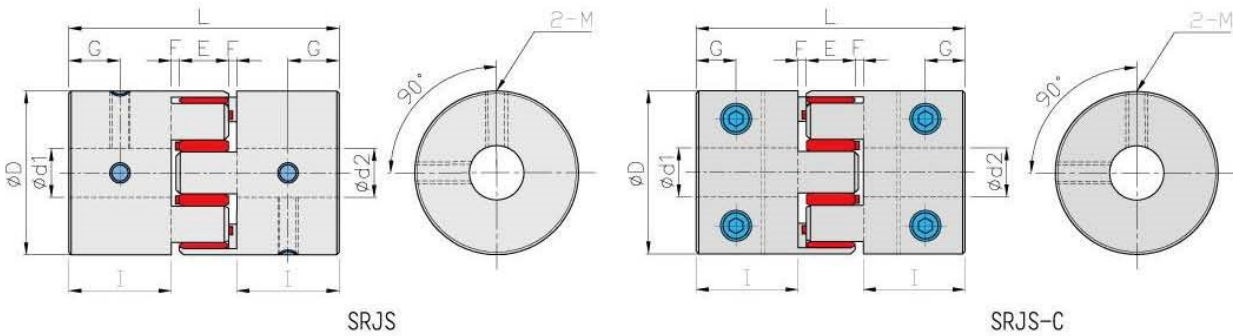

### 尺寸 | Dimension

單位 / Unit:mm

Catalog Number 型號	D	I	L	E	F	G	M	d1xd2 標準孔徑 (H7)		Mass** 重量 (g)
								Min	Max	
SRJS-80-RD	80	45	114	21	1.5	15	M8	38	45	3800
SRJS-80C-RD	80	45	114	21	1.5	15	M8	38	45	3800

### 性能 | Specifications

單位 / Unit:mm

Catalog Number 型號	Rated Torque 一般扭力 (N.m)	Max. Torque 最大扭力 (N.m)	Max Rotational Frequency 最高回轉速 (Rpm/min)	Moment* of Inertia 慣性 (Kg · m <sup>2</sup> )	Errors of Eccentricity 容許偏心 (mm)	Errors of Angularity 容許偏角 (°)
SRJS-80-RD	600	1200	6000	48.57x10 <sup>-6</sup>	0.10	3
SRJS-80C-RD	600	1200	6000	48.57x10 <sup>-6</sup>	0.10	3

# SOT 十字滑動型 / 止付螺絲固定式 / 撓性聯軸器

OLDHAM / SET SCREW TYPE / FLEXIBLE COUPLING



## 材質 | Material

鋁合金 Aluminum alloy  
緩衝材: 尼龍 Buffer material: Nylon

## 表面處理 | Surface Treatment

陽極處理 Anodizing standard white

## 特性 | Features

1. 高剛性
2. 絕緣性佳
3. 組合容易
4. 可吸收較大的偏心偏角
5. 適用溫度環境: -20°C~80°C
6. 固定方式: 止付螺絲固定式

## 型號表示 | Product NO

**SOT-40-**  $\phi 8 \times \phi 8$   
型號 / Type      孔徑 / Inside dia

- High rigid
- High insulation
- Handy assembly
- Larger eccentricity and error of angle deviation allowable
- Operating temperatures: -20°C~80°C
- Fixed mode: Set screw type

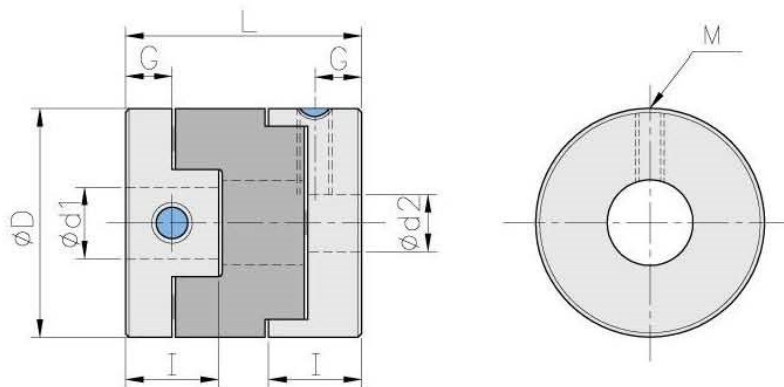

## 尺寸 | Dimension

單位 / Unit:mm

Catalog Number 型號	D	I	L	G	M	d1xd2 標準孔徑 (H7)		Mass** 重量 (g)
						Min	Max	
SOT-16	16	7	18	3.5	M3	4	6.35	7
SOT-20	20	10	22	4.5	M4	5	8	14
SOT-25	25	12	28	5.5	M5	5	10	27
SOT-32	32	14	33	6.5	M6	8	14	50
SOT-40	40	15	35	7.0	M6	10	16	80
SOT-50	50	16.5	38	8.5	M8	14	20	150
SOT-63	63	20.5	47	10.5	M10	15	25	300

## 性能 | Specifications

單位 / Unit:mm

Catalog Number 型號	Rated Torque 一般扭力 (N.m)	Max. Torque 最大扭力 (N.m)	Max Rotational Frequency 最高回轉速 (Rpm/min)	Moment* of Inertia 慣性 (Kg · m <sup>2</sup> )	Errors of Eccentricity 容許偏心 (mm)	Errors of Angularity 容許偏角 (°)
SOT-16	0.7	1.4	9500	3.2x10 <sup>-7</sup>	1.0	3
SOT-20	1.2	2.4	7600	1.0x10 <sup>-6</sup>	1.5	3
SOT-25	2.0	4.0	6100	3.0x10 <sup>-6</sup>	2.0	3
SOT-32	4.5	9.0	4800	9.5x10 <sup>-6</sup>	2.5	3
SOT-40	9.0	18.0	3800	2.3x10 <sup>-5</sup>	3.0	3
SOT-50	18.0	36.0	3100	6.7x10 <sup>-5</sup>	3.5	3
SOT-63	36.0	72.0	2400	2.2x10 <sup>-4</sup>	4.0	3

# SOT-C 十字滑動型 / 夾緊式 / 撓性聯軸器

OLDHAM / CLAMP TYPE / FLEXIBLE COUPLING



### 材質 | Material

鋁合金 Aluminum alloy  
緩衝材: 尼龍 Buffer material : Nylon

### 表面處理 | Surface Treatment

陽極處理 Anodizing standard white

### 特性 | Features

1. 高剛性
2. 絕緣性佳
3. 組合容易
4. 可吸收較大的偏心偏角
5. 適用溫度環境: -20°C~80°C
6. 固定方式: 夾緊式

### 型號表示 | Product NO

**SOT-40C-**  $\varnothing 8 \times \varnothing 8$   
型號 / Type      孔徑 / Inside dia

- High rigid
- High insulation
- Handy assembly
- Larger eccentricity and error of angle deviation allowable
- Operating temperatures: -20°C~80°C
- Fixed mode: Clamp type

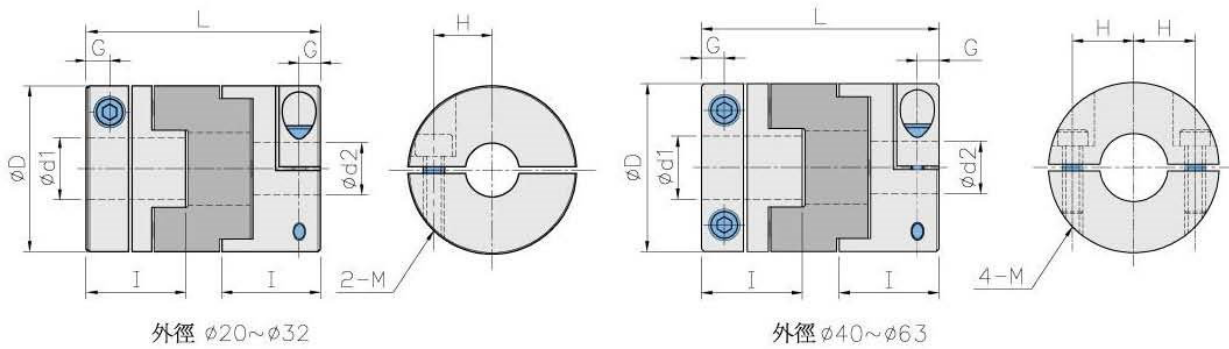

### 尺寸 | Dimension

單位 / Unit:mm

Catalog Number 型號	D	I	L	G	H	M	d1xd2 標準孔徑 (H7)		Mass** 重量 (g)
							Min	Max	
SOT-16C	16	13	29	3.0	5.0	M2.5	4	6.35	12
SOT-20C	20	15	33	3.0	6.5	M3	5	8.0	19
SOT-25C	25	18	39	3.8	9.0	M3	5	10.0	36
SOT-32C	32	20	45	4.5	11.0	M4	6	14.0	69
SOT-40C	40	22.5	50	7.0	13.0	M5	8	16.0	130
SOT-50C	50	26.5	58	8.0	16.0	M6	12	22.0	230
SOT-63C	63	32.5	71	10.0	21.0	M8	15	25.0	450

### 性能 | Specifications

單位 / Unit:mm

Catalog Number 型號	Rated Torque 一般扭力 (N.m)	Max. Torque 最大扭力 (N.m)	Max Rotational Frequency 最高回轉速 (Rpm/min)	Moment* of Inertia 慣性 (Kg · m <sup>2</sup> )	Errors of Eccentricity 容許偏心 (mm)	Errors of Angularity 容許偏角 (°)
SOT-16C	0.7	1.4	9500	5.8x10 <sup>-7</sup>	1.0	3
SOT-20C	1.2	2.4	7600	1.5x10 <sup>-6</sup>	1.5	3
SOT-25C	2.0	4.0	6100	4.4x10 <sup>-6</sup>	2.0	3
SOT-32C	4.5	9.0	4800	1.4x10 <sup>-5</sup>	2.5	3
SOT-40C	9.0	18.0	3800	4.1x10 <sup>-5</sup>	3.0	3
SOT-50C	18.0	36.0	3100	1.2x10 <sup>-5</sup>	3.5	3
SOT-63C	36.0	72.0	2400	3.7x10 <sup>-4</sup>	4.0	3

# SCG

## 止付螺絲固定式 / 剛性聯軸器

# SCGS

## SET SCREW TYPE / RIGID COUPLER



### 材質 | Material

SCG 系列-鋁合金 Aluminum alloy  
 SCGS 系列-不銹鋼 Stainless steel

### 表面處理 | Surface Treatment

陽極處理 Anodizing standard white

### 特性 | Features

1. 一體成型
2. 超高剛性
3. 高扭力
4. 低慣性
5. 固定方式：止付螺絲固定式

型號表示 | Product NO

**SCG-20 -  $\varnothing 6 \times \varnothing 6$**

型號 / Type      孔徑 / Inside dia

- One-body shape
- Super high rigid
- High torque
- Low inertia
- Fixed mode : Set screw type

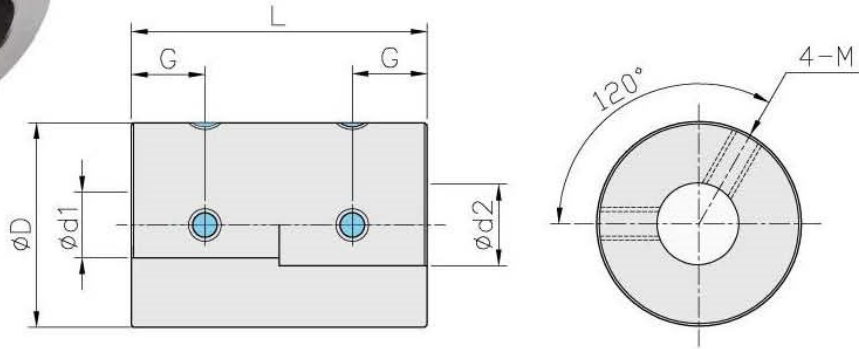

### 尺寸 | Dimension

Catalog Number 型號	D	L	G	M	d1xd2 標準孔徑 (H7)		Mass** 重量 (g)
					Min	Max	
					SCG-16	16	
SCG-20	20	30	7	M4	6	10	20
SCG-25	25	36	9	M4	6	12	39
SCG-32	32	41	10	M5	8	16	71
SCGS-16	16	24	6	M3	5	8	31
SCGS-20	20	30	7	M4	6	10	53
SCGS-25	25	36	9	M4	6	12	105
SCGS-32	32	41	10	M5	8	16	190

### 性能 | Specifications

Catalog Number 型號	Rated Torque 一般扭力 (N.m)	Max. Torque 最大扭力 (N.m)	Max Rotational Frequency 最高回轉速 (Rpm/min)	Moment* of Inertia 慣性 (Kg · m <sup>2</sup> )
SCG-16	0.3	0.6	24000	4.4x10 <sup>-7</sup>
SCG-20	0.5	1.0	19000	1.3x10 <sup>-6</sup>
SCG-25	1.0	2.0	15000	3.9x10 <sup>-6</sup>
SCG-32	2.0	4.0	12000	1.2x10 <sup>-5</sup>
SCGS-16	0.3	0.6	24000	1.2x10 <sup>-6</sup>
SCGS-20	0.5	1.0	19000	3.5x10 <sup>-6</sup>
SCGS-25	1.0	2.0	15000	1.0x10 <sup>-5</sup>
SCGS-32	2.0	4.0	12000	3.1x10 <sup>-5</sup>

# SCG-C

夾緊式 / 剛性聯軸器

# SCGS-C

CLAMP TYPE / RIGID COUPLING



SCG-C

SCGS-C

### 材質 | Material

SCG-C系列-鋁合金 Aluminum alloy  
SCGS-C系列-不銹鋼 Stainless steel

### 表面處理 | Surface Treatment

陽極處理 Anodizing standard white

### 特性 | Features

1. 一體成型
2. 超高剛性
3. 高扭力
4. 低慣性
5. 固定方式：夾緊式

### 型號表示 | Product NO

**SCG-20C** -  $\phi 6 \times \phi 6$

型號 / Type

孔徑 / Inside dia

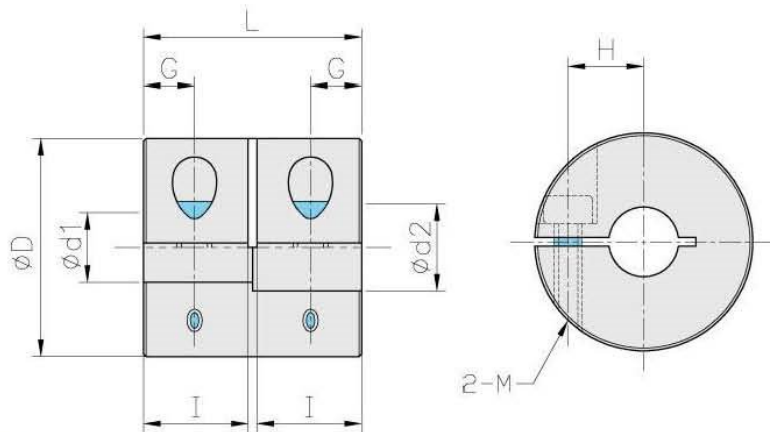

### 尺寸 | Dimension

單位 / Unit:mm

Catalog Number 型號	D	I	L	G	H	M	d1xd2 標準孔徑 (H7)		Mass** 重量 (g)
							Min	Max	
SCG-16C	16	7.5	16	3.75	5	M2.5	5	6	11
SCG-20C	20	9.5	20	4.75	6.5	M3	6	8	20
SCG-25C	25	12	25	6	9	M4	6	10	39
SCG-32C	32	15.5	32	7.75	11	M4	8	14	71
SCGS-16C	16	7.5	16	3.75	5	M2.5	5	6	31
SCGS-20C	20	9.5	20	4.75	6.5	M3	6	8	53
SCGS-25C	25	12	25	6	9	M4	6	10	85
SCGS-32C	32	15.5	32	7.75	11	M4	8	14	190

### 性能 | Specifications

單位 / Unit:mm

Catalog Number 型號	Rated Torque 一般扭力 (N.m)	Max. Torque 最大扭力 (N.m)	Max Rotational Frequency 最高回轉速 (Rpm/min)	Moment* of Inertia 慣性 (Kg · m <sup>2</sup> )
SCG-16C	0.3	0.6	9500	3.0x10 <sup>-7</sup>
SCG-20C	0.5	1.0	7600	8.7x10 <sup>-7</sup>
SCG-25C	1.0	2.0	6100	2.7x10 <sup>-6</sup>
SCG-32C	2.0	4.0	4800	7.1x10 <sup>-6</sup>
SCGS-16C	0.3	0.6	9500	8.0x10 <sup>-7</sup>
SCGS-20C	0.5	1.0	7600	2.4x10 <sup>-6</sup>
SCGS-25C	1.0	2.0	6100	7.3x10 <sup>-5</sup>
SCGS-32C	2.0	4.0	4800	2.5x10 <sup>-5</sup>

# 標準孔徑鍵槽加工規格

## STANDARD APERTURE KEYWAY PROCESSING SPECIFICATIONS

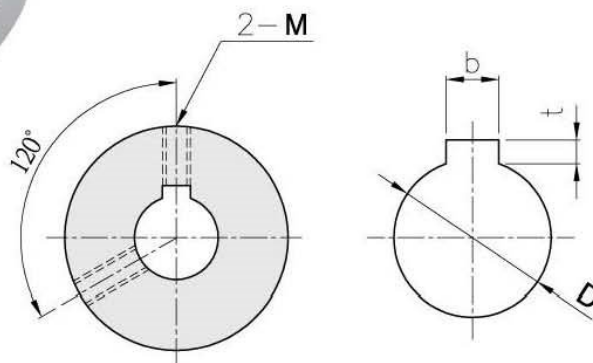

型號表示 | Product NO

**SCT-50** -  $\varnothing 14$  K6 x 2.3  
 $\varnothing 20$  K6 x 2.3

型號 / Type      孔徑 / Inside dia

### 尺寸 | Dimension

單位 / Unit: mm

Stock Bores 標準孔徑 D	鍵槽 Keyways				鍵 尺寸 b x h
	b		t		
	基準 寸法	容許差 (Js9)	基準 寸法	容許差	
10	3	$\pm 0.015$	1.5	$\begin{matrix} +0.1 \\ 0 \end{matrix}$	3 x 3
12	4	$\pm 0.015$	1.8	$\begin{matrix} +0.1 \\ 0 \end{matrix}$	4 x 4
14~18	5	$\pm 0.015$	2.3	$\begin{matrix} +0.1 \\ 0 \end{matrix}$	5 x 5
19~22	6	$\pm 0.015$	2.8	$\begin{matrix} +0.1 \\ 0 \end{matrix}$	6 x 6
24~30	8	$\pm 0.030$	3.3	$\begin{matrix} +0.2 \\ 0 \end{matrix}$	8 x 7
30~38	10	$\pm 0.030$	3.3	$\begin{matrix} +0.2 \\ 0 \end{matrix}$	10 x 8
38~44	12	$\pm 0.030$	3.3	$\begin{matrix} +0.2 \\ 0 \end{matrix}$	12 x 8
44~50	14	$\pm 0.043$	3.8	$\begin{matrix} +0.3 \\ 0 \end{matrix}$	14 x 9
50~58	16	$\pm 0.043$	4.3	$\begin{matrix} +0.3 \\ 0 \end{matrix}$	16 x 10
58~65	18	$\pm 0.043$	4.4	$\begin{matrix} +0.3 \\ 0 \end{matrix}$	18 x 11

## 參考資料

### REFERENCE DATA

#### 扭力換算表 | Torque conversion form

單位	英制 English Unit		國際標準公制 International System of Units	
	Kgf-cm	Kgf-m	N.cm	N.m
Kgf-cm	1	0.01	9.807	0.098
Kgf-m	100	1	980.7	9.807
N.cm	0.102	0.001	1	0.01
N.m	10.2	0.102	100	1

#### 一般馬達規格表 | Motor specification

OUTPUT 輸出		2極 2-Pole				4極 4-Pole					
千瓦 (K.w.)	馬力 (H.p.)	軸徑 Shaft Dia (mm)	50Hz		60Hz		軸徑 Shaft Dia (mm)	50Hz		60Hz	
			扭力 Torque (K.g.m)	轉速 Frequency (R.p.m)	扭力 Torque (K.g.m)	轉速 Frequency (R.p.m)		扭力 Torque (K.g.m)	轉速 Frequency (R.p.m)	扭力 Torque (K.g.m)	轉速 Frequency (R.p.m)
0.20	0.25	11	0.07	3000	0.06	3600	11	0.13	1500	0.11	1800
0.40	0.50	14	0.13		0.11		14	0.25		0.21	
0.75	1.00	19	0.24		0.20		19	0.49		0.41	
1.50	2.00	24	0.49		0.41		24	0.97		0.81	
2.20	3.00	24	0.71		0.59		24	1.40		1.20	
3.70	5.00	28	1.20		1.00		28	2.40		2.00	
5.50	7.50	38	1.80		1.50		38	3.60		3.00	
7.50	10.00	38	2.40		2.00		38	4.90		4.10	
11.00	15.00	42	3.60		3.00		42	7.10		6.00	
15.00	20.00	42	4.90		4.10		42	9.70		8.10	
18.50	25.00	42	6.00	5.00	42	12.00	10.00				
22.00	30.00	48	7.10	6.00	48	14.30	11.90				
30.00	40.00	55	9.70	8.10	55	19.50	16.20				



# 孔徑公差表

## APERTURE TOLERANCES FORM

單位：μm

尺寸範圍 (mm)	E			F			G			H							Js		J			K			M			N			P		R	
	E7	E8	E9	F6	F7	F8	G6	G7	G8	H5	H6	H7	H8	H9	H10	Js6	Js7	J6	J7	K6	K7	M6	M7	N6	N7	P7	R7	R7						
3 ~ 6	+32 +20	+38 +20	+50 +20	+18 +10	+22 +10	+28 +10	+12 +4	+16 +4	+5 0	+8 0	+12 0	+18 0	+30 0	+48 0	±4	±6	+5 -3	+6 -6	+2 -6	+3 -9	-1 -9	0 -12	-5 -13	-4 -16	-8 -20	-11 -23	-4 -16	-8 -20	-11 -23					
6 ~ 10	+40 +25	+47 +25	+61 +25	+22 +13	+28 +13	+35 +13	+14 +5	+20 +5	+6 0	+9 0	+15 0	+22 0	+36 0	+58 0	±4.5	±7.5	+5 -4	+8 -7	+2 -7	+5 -10	-3 -12	0 -15	-3 -16	-4 -19	-9 -24	-13 -28	-4 -19	-9 -24	-13 -28					
10 ~ 14	+50 +32	+59 +32	+75 +32	+27 +16	+34 +16	+43 +16	+17 +6	+24 +6	+8 0	+11 0	+18 0	+27 0	+43 0	+70 0	±5.5	±9	+6 -5	+10 -8	+2 -9	+5 -12	-4 -18	0 -23	-4 -23	-5 -23	-9 -29	-11 -34	-5 -23	-9 -29	-11 -34					
14 ~ 18	+61 +40	+73 +40	+92 +40	+33 +20	+41 +20	+53 +20	+20 +7	+28 +7	+9 0	+13 0	+21 0	+33 0	+52 0	+84 0	±6.5	±10.5	+8 -5	+12 -9	+2 -11	+6 -15	-4 -21	0 -17	-4 -28	-11 -35	-7 -41	-14 -30	-7 -41	-14 -30	-20 -41					
18 ~ 24	+75 +50	+89 +50	+112 +50	+41 +25	+50 +25	+64 +25	+25 +9	+34 +9	+11 0	+16 0	+25 0	+39 0	+62 0	+100 0	±8	±12.5	+10 -6	+14 -11	+3 -13	+7 -18	-4 -25	-4 -25	0 -25	-12 -33	-8 -42	-17 -50	-8 -42	-17 -50	-25 -50					
30 ~ 40	+75 +50	+89 +50	+112 +50	+41 +25	+50 +25	+64 +25	+25 +9	+34 +9	+11 0	+16 0	+25 0	+39 0	+62 0	+100 0	±8	±12.5	+10 -6	+14 -11	+3 -13	+7 -18	-4 -25	-4 -25	0 -25	-12 -33	-8 -42	-17 -50	-8 -42	-17 -50	-25 -50					
40 ~ 50	+90 +60	+106 +60	+134 +60	+49 +30	+60 +30	+76 +30	+29 +10	+40 +10	+13 0	+19 0	+30 0	+46 0	+74 0	+120 0	±9.5	±15	+13 -6	+18 -12	+4 -15	+9 -21	-5 -24	0 -30	-5 -30	-14 -33	-9 -39	-21 -51	-9 -39	-21 -51	-30 -62					
50 ~ 65	+90 +60	+106 +60	+134 +60	+49 +30	+60 +30	+76 +30	+29 +10	+40 +10	+13 0	+19 0	+30 0	+46 0	+74 0	+120 0	±9.5	±15	+13 -6	+18 -12	+4 -15	+9 -21	-5 -24	0 -30	-5 -30	-14 -33	-9 -39	-21 -51	-9 -39	-21 -51	-30 -62					
65 ~ 80	+107 +72	+126 +72	+159 +72	+58 +36	+71 +36	+90 +36	+34 +12	+47 +12	+15 0	+22 0	+35 0	+54 0	+87 0	+140 0	±11	±17.5	+16 -6	+22 -13	+4 -18	+10 -25	-5 -35	0 -28	-5 -35	-16 -45	-10 -45	-24 -59	-10 -45	-24 -59	-38 -76					
80 ~ 100	+107 +72	+126 +72	+159 +72	+58 +36	+71 +36	+90 +36	+34 +12	+47 +12	+15 0	+22 0	+35 0	+54 0	+87 0	+140 0	±11	±17.5	+16 -6	+22 -13	+4 -18	+10 -25	-5 -35	0 -28	-5 -35	-16 -45	-10 -45	-24 -59	-10 -45	-24 -59	-38 -76					
100 ~ 120	+125 +85	+148 +85	+185 +85	+68 +43	+83 +43	+106 +43	+39 +14	+54 +14	+18 0	+25 0	+40 0	+63 0	+100 0	+160 0	±12.5	±20	+18 -7	+26 -14	+4 -21	+12 -28	-8 -33	0 -40	-8 -40	-20 -45	-12 -52	-28 -68	-12 -52	-28 -68	-50 -90					
120 ~ 140	+146 +100	+172 +100	+215 +100	+79 +50	+96 +50	+122 +50	+44 +15	+61 +15	+20 0	+29 0	+46 0	+72 0	+115 0	+185 0	±14.5	±23	+22 -7	+30 -16	+5 -24	+13 -33	-8 -37	0 -46	-8 -46	-22 -51	-14 -60	-33 -79	-14 -60	-33 -79	-60 -109					
140 ~ 160	+146 +100	+172 +100	+215 +100	+79 +50	+96 +50	+122 +50	+44 +15	+61 +15	+20 0	+29 0	+46 0	+72 0	+115 0	+185 0	±14.5	±23	+22 -7	+30 -16	+5 -24	+13 -33	-8 -37	0 -46	-8 -46	-22 -51	-14 -60	-33 -79	-14 -60	-33 -79	-60 -109					
160 ~ 180	+162 +110	+191 +110	+240 +110	+88 +56	+108 +56	+137 +56	+49 +17	+69 +17	+23 0	+32 0	+52 0	+81 0	+130 0	+210 0	±16	±26	+25 -7	+36 -16	+5 -27	+16 -36	-9 -41	0 -52	-9 -52	-25 -57	-14 -66	-33 -88	-14 -66	-33 -88	-74 -130					
180 ~ 200	+162 +110	+191 +110	+240 +110	+88 +56	+108 +56	+137 +56	+49 +17	+69 +17	+23 0	+32 0	+52 0	+81 0	+130 0	+210 0	±16	±26	+25 -7	+36 -16	+5 -27	+16 -36	-9 -41	0 -52	-9 -52	-25 -57	-14 -66	-33 -88	-14 -66	-33 -88	-74 -130					
200 ~ 225	+182 +125	+214 +125	+265 +125	+98 +62	+119 +62	+151 +62	+54 +18	+75 +18	+25 0	+36 0	+57 0	+89 0	+140 0	+230 0	±18	±28.5	+29 -7	+39 -18	+7 -29	+17 -40	-10 -46	0 -57	-10 -57	-26 -62	-16 -73	-41 -98	-16 -73	-41 -98	-87 -150					
225 ~ 250	+182 +125	+214 +125	+265 +125	+98 +62	+119 +62	+151 +62	+54 +18	+75 +18	+25 0	+36 0	+57 0	+89 0	+140 0	+230 0	±18	±28.5	+29 -7	+39 -18	+7 -29	+17 -40	-10 -46	0 -57	-10 -57	-26 -62	-16 -73	-41 -98	-16 -73	-41 -98	-87 -150					
250 ~ 280	+198 +135	+232 +135	+290 +135	+108 +68	+131 +68	+165 +68	+60 +20	+83 +20	+27 0	+40 0	+63 0	+97 0	+155 0	+250 0	±20	±31.5	+33 -7	+43 -20	+8 -32	+18 -45	-10 -50	0 -63	-10 -63	-27 -67	-17 -80	-45 -108	-17 -80	-45 -108	-103 -172					
280 ~ 315	+198 +135	+232 +135	+290 +135	+108 +68	+131 +68	+165 +68	+60 +20	+83 +20	+27 0	+40 0	+63 0	+97 0	+155 0	+250 0	±20	±31.5	+33 -7	+43 -20	+8 -32	+18 -45	-10 -50	0 -63	-10 -63	-27 -67	-17 -80	-45 -108	-17 -80	-45 -108	-103 -172					
315 ~ 355	+198 +135	+232 +135	+290 +135	+108 +68	+131 +68	+165 +68	+60 +20	+83 +20	+27 0	+40 0	+63 0	+97 0	+155 0	+250 0	±20	±31.5	+33 -7	+43 -20	+8 -32	+18 -45	-10 -50	0 -63	-10 -63	-27 -67	-17 -80	-45 -108	-17 -80	-45 -108	-103 -172					
355 ~ 400	+198 +135	+232 +135	+290 +135	+108 +68	+131 +68	+165 +68	+60 +20	+83 +20	+27 0	+40 0	+63 0	+97 0	+155 0	+250 0	±20	±31.5	+33 -7	+43 -20	+8 -32	+18 -45	-10 -50	0 -63	-10 -63	-27 -67	-17 -80	-45 -108	-17 -80	-45 -108	-103 -172					
400 ~ 450	+198 +135	+232 +135	+290 +135	+108 +68	+131 +68	+165 +68	+60 +20	+83 +20	+27 0	+40 0	+63 0	+97 0	+155 0	+250 0	±20	±31.5	+33 -7	+43 -20	+8 -32	+18 -45	-10 -50	0 -63	-10 -63	-27 -67	-17 -80	-45 -108	-17 -80	-45 -108	-103 -172					
450 ~ 500	+198 +135	+232 +135	+290 +135	+108 +68	+131 +68	+165 +68	+60 +20	+83 +20	+27 0	+40 0	+63 0	+97 0	+155 0	+250 0	±20	±31.5	+33 -7	+43 -20	+8 -32	+18 -45	-10 -50	0 -63	-10 -63	-27 -67	-17 -80	-45 -108	-17 -80	-45 -108	-103 -172					